

### Merkmale

Übersetzungen:  $i = 1:1$  bis  $6:1$

Maximales Abtriebsmoment 5400 Nm

9 Getriebegrößen von 065 bis 350 mm Kantenlänge

Spielarm in der Ausführung < 6 Winkelminuten möglich

Gehäuse aus Grauguss oder Stahl

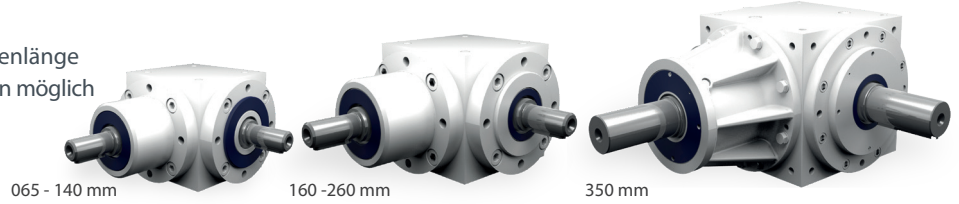

### Bauarten

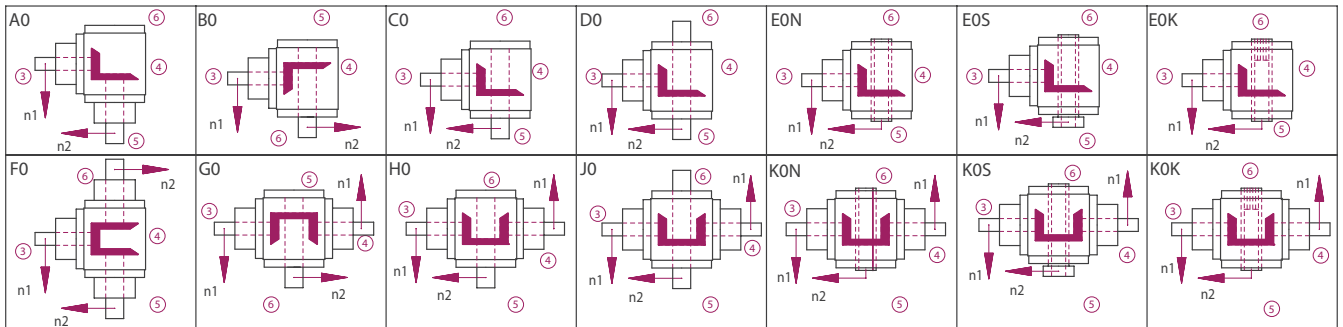

### Getriebeseiten

Im Beispiel dargestellt ist die Bauart C0

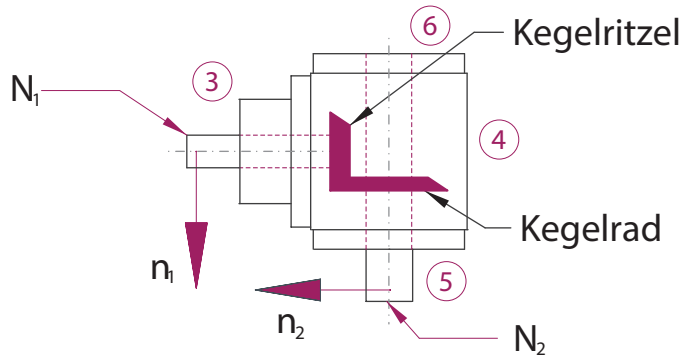
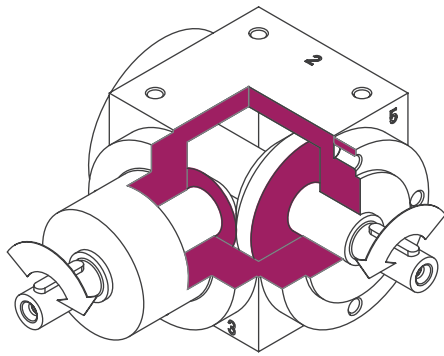

### Bestellbezeichnung

Die Bestellbezeichnung spiegelt die Kundenangaben wieder.

Beispiel:

Typ	Größe	Übersetzung	Bauart	Befestigungsseite	Einbaulage	Drehzahl $n_2$	Ausführung
V	065	1:1	C0-	1.	1-	1500	/A0
Beschreibung	Gehäuse-Kantenlänge; Tabelle 6.3.5-1	Tabelle 6.3.5-1	Abbildung 6.3.2-1; Bauarten	Getriebeseite an der befestigt wird; Tabelle 6.2.3-1; Abbildung 4.2.1-1 Getriebeseiten	Nach unten zeigende Getriebeseite; Abbildung 4.2.1-1; Getriebeseiten	Langsamlaufende Welle; Tabelle 6.3.5-1	Standard

# Übersicht Leistungsdaten

Größe	1:1				1,5:1			2:1			3:1			4:1			5:1			6:1			
	n <sub>1</sub> [1/min]	n <sub>2</sub> [1/min]	P <sub>1N</sub> [kW]	T <sub>2N</sub> [Nm]	n <sub>2</sub> [1/min]	P <sub>1N</sub> [kW]	T <sub>2N</sub> [Nm]	n <sub>2</sub> [1/min]	P <sub>1N</sub> [kW]	T <sub>2N</sub> [Nm]	n <sub>2</sub> [1/min]	P <sub>1N</sub> [kW]	T <sub>2N</sub> [Nm]	n <sub>2</sub> [1/min]	P <sub>1N</sub> [kW]	T <sub>2N</sub> [Nm]	n <sub>2</sub> [1/min]	P <sub>1N</sub> [kW]	T <sub>2N</sub> [Nm]	n <sub>2</sub> [1/min]	P <sub>1N</sub> [kW]	T <sub>2N</sub> [Nm]	
065	3000	3000	3,31	10	2000	2,20	10	1500	1,65	10	1000	1,10	10										
	2400	2400	2,65	10	1600	1,76	10	1200	1,32	10	800	0,88	10										
	1500	1500	1,82	11	1000	1,21	11	750	0,91	11	500	0,61	11										
	1000	1000	1,32	12	667	0,88	12	500	0,66	12	333	0,44	12										
	750	750	1,07	13	500	0,72	13	375	0,54	13	250	0,33	12										
	500	500	0,83	15	333	0,55	15	250	0,41	15	167	0,24	13										
	250	250	0,47	17	167	0,31	17	125	0,23	17	83	0,12	13										
	50	50	0,10	18	33	0,07	18	25	0,05	18	17	0,03	14										
090	3000	3000	8,93	27	2000	5,51	25	1500	3,80	23	1000	2,54	23	750	1,90	23	600	1,52	23	500	1,25	23	
	2400	2400	7,41	28	1600	4,59	26	1200	3,17	24	800	2,12	24	600	1,65	25	480	1,32	25	400	1,09	25	
	1500	1500	5,29	32	1000	3,20	29	750	2,23	27	500	1,49	27	375	1,12	27	300	0,89	27	250	0,74	27	
	1000	1000	3,75	34	667	2,35	32	500	1,71	31	333	1,14	31	250	0,85	31	200	0,68	31	167	0,53	29	
	750	750	3,06	37	500	1,93	35	375	1,32	32	250	0,88	32	188	0,66	32	150	0,53	32	125	0,40	29	
	500	500	2,20	40	333	1,36	37	250	0,94	34	167	0,63	34	125	0,47	34	100	0,37	34	83	0,27	29	
	250	250	1,21	44	167	0,74	40	125	0,50	36	83	0,33	36	63	0,25	36	50	0,20	36	42	0,14	30	
	50	50	0,28	50	33	0,16	45	25	0,10	37	17	0,07	37	13	0,05	37	10	0,04	37	8	0,03	33	
120	3000	3000	21,82	66	2000	13,45	61	1500	9,26	56	1000	6,39	58	750	4,96	60	600	3,97	60	500	2,95	54	
	2400	2400	18,52	70	1600	11,46	65	1200	8,07	61	800	5,56	63	600	4,43	67	480	3,44	65	400	2,53	57	
	1500	1500	13,56	82	1000	8,60	78	750	6,03	73	500	4,08	74	375	3,06	74	300	2,38	72	250	1,75	64	
	1000	1000	10,14	92	667	6,32	86	500	4,46	81	333	3,01	82	250	2,18	79	200	1,76	80	167	1,22	66	
	750	750	8,51	103	500	5,18	94	375	3,55	86	250	2,40	87	188	1,69	82	150	1,42	86	125	0,94	68	
	500	500	6,34	115	333	3,85	100	250	2,54	92	167	1,66	90	125	1,16	84	100	0,98	89	83	0,63	69	
	250	250	3,39	123	167	1,99	100	125	1,35	98	83	0,87	95	63	0,60	87	50	0,51	92	42	0,33	71	
	50	50	0,72	130	33	0,41	100	25	0,29	107	17	0,21	110	13	0,12	90	10	0,10	95	8	0,06	66	
140	3000	3000	39,68	120	2000	24,91	113	1500	16,53	100	1000	12,12	110	750	8,51	103	600	6,61	100	500	5,18	94	
	2400	2400	37,04	140	1600	22,22	126	1200	14,68	111	800	11,46	130	600	7,34	111	480	5,56	105	400	4,58	104	
	1500	1500	26,78	162	1000	17,08	155	750	11,41	138	500	8,05	146	375	4,96	120	300	3,80	115	250	2,95	107	
	1000	1000	20,28	184	667	12,87	175	500	8,38	152	333	5,87	160	250	3,75	136	200	2,73	124	167	2,06	112	
	750	750	16,20	196	500	10,47	190	375	6,86	166	250	4,60	167	188	3,06	148	150	2,15	130	125	1,61	117	
	500	500	11,46	208	333	7,34	200	250	4,96	180	167	3,20	174	125	2,12	154	100	1,50	136	83	1,09	119	
	250	250	5,92	215	167	3,76	204	125	2,62	190	83	1,62	177	63	1,12	162	50	0,79	143	42	0,56	121	
	50	50	1,21	220	33	0,76	210	25	0,55	200	17	0,34	180	13	0,23	170	10	0,17	150	8	0,11	120	
160	3000				2000	40,78	185	1500	28,11	170	1000	20,94	190	750	14,88	180	600	11,90	180	500	7,09	129	
	2400	2400	57,67	218	1600	36,15	205	1200	25,53	193	800	17,81	202	600	13,23	200	480	10,48	198	400	5,98	136	
	1500	1500	42,99	260	1000	27,78	252	750	20,25	245	500	12,68	230	375	9,09	220	300	7,11	215	250	3,95	143	
	1000	1000	31,96	290	667	20,59	280	500	14,88	270	333	8,99	245	250	6,61	240	200	4,96	225	167	3,01	164	
	750	750	25,63	310	500	16,26	295	375	11,57	280	250	6,89	250	188	5,17	250	150	3,97	240	125	2,43	176	
	500	500	18,19	330	333	11,56	315	250	8,27	300	167	4,79	260	125	3,58	260	100	2,76	250	83	1,72	187	
	250	250	9,64	350	167	6,07	330	125	4,41	320	83	2,56	280	63	1,86	270	50	1,49	270	42	0,92	199	
	50	50	2,09	380	33	1,29	355	25	0,98	355	17	0,57	305	13	0,39	280	10	0,32	290	8	0,18	197	
200	3000				2000	72,75	330	1500	51,25	310	1000	46,29	420	750	28,93	350	600	19,84	300	500	11,45	208	
	2400				1600	63,49	360	1200	45,24	342	800	39,24	445	600	26,45	400	480	17,99	340	400	9,60	218	
	1500	1500	74,40	450	1000	48,17	437	750	35,13	425	500	28,38	515	375	18,81	455	300	12,57	380	250	6,54	237	
	1000	1000	56,21	510	667	37,13	505	500	27,56	500	333	20,37	555	250	13,36	485	200	9,26	420	167	4,74	258	
	750	750	45,88	555	500	30,31	550	375	22,32	540	250	15,98	580	188	10,54	510	150	7,27	440	125	3,98	289	
	500	500	34,17	620	333	22,57	615	250	16,81	610	167	11,04	600	125	7,23	525	100	5,18	470	83	2,79	304	
	250	250	19,56	710	167	12,70	690	125	9,37	680	83	5,76	630	63	3,79	550	50	2,78	505	42	1,44	311	
	50	50	4,13	750	33	2,73	750	25	2,07	750	17	1,29	690	13	0,80	580	10	0,58	525	8	0,28	306	
230	3000				2000	99,20	450	1500	87,63	530	1000	44,09	400	750	36,37	440	600	33,73	510	500	20,17	366	
	2400				1600	91,35	518	1200	80,02	605	800	39,68	450	600	32,74	495	480	29,10	550	400	18,08	410	
	1500	1500	87,63	530	1000	72,20	655	750	59,11	715	500	29,76	540	375	24,80	600	300	21,00	635	250	13,50	490	
	1000	1000	71,65	650	667	56,21	765	500	45,19	820	333	23,33	635	250	18,60	675	200	15,76	715	167	9,92	540	
	750	750	60,76	735	500	45,47	825	375	36,79	890	250	19,29	700	188	15,19	735	150	12,73	770	125	7,78	565	
	500	500	45,19	820	333	33,79	920	250	26,73	970	167	14,07	765	125	10,95	795	100	9,15	830	83	5,42	590	
	250	250	26,73	970	167	20,57	1120	125	16,88	1225	83	7,58	825	63	5,99	870	50	5,07	920	42	2,82	610	
	50	50	7,00	1270	33	4,89	1330	25	3,66	1330	17	1,63	870	13	1,35	980	10	1,09	990	8	0,57	625	
260	3000				2000	189,58	860	1500	133,92	810	1000	85,97	780	750	57,87	700	600	46,29	700	500	27,27	495	
	2400				1600	158,72	900	1200	112,43	850	800	72,39	821	600	51,58	780	480	40,21	760	400	23,12	524	
	1500	1500	157,07	950	1000	104,71	950	750	78,53	950	500	49,60	900	375	37,20	900	300	29,10	880	250	16,36	594	
	1000	1000	115,73	1050	667	77,19	1050	500	57,87	1050	333	36,34	990	250	28,93	1050	200	21,82	990	167	12,93	702	
	750	750	96,72	1170	500	64,48	1170	375	48,36	1170	250	28,93	1050	188	22,73	1100	150	18,19	1100	125	10,91	792	
	500	500	72,75	1320	333	47,72	1300	250	35,27	1280	167	20,43	1110	125	16,26	1180	100	13,23	1200	83	8,06	878	
	250	250	42,44	1540	167	27,43	1490	125	20,12	1460	83	11,16	1220	63	8,61	1250	50	7,11	1290	42	4,35	940	
	50	50	9,64	1750	33	6,18	1700	25	4,55	1650	17	2,55	1360	13	1,82	1320	10	1,47	1330				

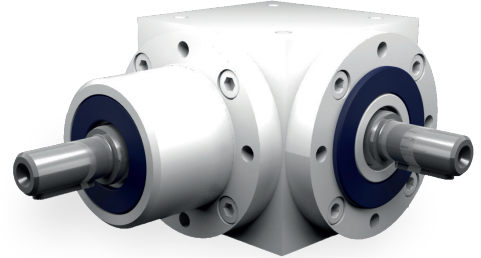

### Eigenschaften

Eigenschaft	Standard
Verzahnung	Kegelradsatz, spiralverzahnt
Gehäuse / Flansche	Grauguss; Stahl
Befestigungs-Gewindebohrung	An allen Gehäuseflächen ohne Flansch und an allen Flanschen.
Welle	Werkstoff 1 C 45, Wellenenden gefettet Passung mit der Toleranz ISO 6 mit Passfedernut: nach DIN 6885 Blatt 1
Hohlwelle	Werkstoff 1 C 45, Wellenenden gefettet Passung mit der Toleranz ISO 7 mit Passfedernut nach DIN 6885 Blatt 1
Radial- Wellendichtring	NBR Form A
Umgebungstemperatur	- 10°C bis + 90°C. Die Werte der Leistungstabellen gelten für + 20°C
Verdreh-Flankenspiel	< 30 arcmin
Schutzklasse	IP 31
Korrosionsschutz	Grundierung; Schichtdicke > 40 µm
Lagerlebensdauer L10h	größer als 15.000 h
Ölwechselintervalle	Bei Einhaltung der Öltemperatur von < 90°C nicht erforderlich Die Lebensdauer der Lager kann um den Faktor 1,5 gesteigert werden, wenn nach den ersten 500 Betriebsstunden und dann alle 5000 Betriebsstunden ein Ölwechsel erfolgt.
Schmierstoff	Synthetische Schmierstoffe

## Leistungsdaten

n <sub>1</sub> [1/min]	1:1			1,5:1			2:1			3:1			4:1			5:1			6:1					
	n <sub>2</sub> [1/min]	P <sub>1N</sub> [kW]	T <sub>2N</sub> [Nm]	n <sub>2</sub> [1/min]	P <sub>1N</sub> [kW]	T <sub>2N</sub> [Nm]	n <sub>2</sub> [1/min]	P <sub>1N</sub> [kW]	T <sub>2N</sub> [Nm]	n <sub>2</sub> [1/min]	P <sub>1N</sub> [kW]	T <sub>2N</sub> [Nm]	n <sub>2</sub> [1/min]	P <sub>1N</sub> [kW]	T <sub>2N</sub> [Nm]	n <sub>2</sub> [1/min]	P <sub>1N</sub> [kW]	T <sub>2N</sub> [Nm]	n <sub>2</sub> [1/min]	P <sub>1N</sub> [kW]	T <sub>2N</sub> [Nm]			
3000	3000	3,31	10	2000	2,20	10	1500	1,65	10	1000	1,10	10												
2400	2400	2,65	10	1600	1,76	10	1200	1,32	10	800	0,88	10												
1500	1500	1,82	11	1000	1,21	11	750	0,91	11	500	0,61	11												
1000	1000	1,32	12	667	0,88	12	500	0,66	12	333	0,44	12												
750	750	1,07	13	500	0,72	13	375	0,54	13	250	0,33	12												
500	500	0,83	15	333	0,55	15	250	0,41	15	167	0,24	13												
250	250	0,47	17	167	0,31	17	125	0,23	17	83	0,12	13												
50	50	0,10	18	33	0,07	18	25	0,05	18	17	0,03	14												
P <sub>1Nt</sub> [kW]	1,6			1,6			1,6			1,6														
T <sub>2max</sub> [Nm]	25			25			25			23														

## Zulässige Radialkraft F<sub>r1</sub> und Axialkraft F<sub>a1</sub> an der Welle N<sub>1</sub>

n <sub>1</sub> [1/min]	3000		1000		500		250		100		50	
T <sub>2</sub> [Nm]	F <sub>r</sub> [N]	F <sub>a</sub> [N]	F <sub>r</sub> [N]	F <sub>a</sub> [N]	F <sub>r</sub> [N]	F <sub>a</sub> [N]	F <sub>r</sub> [N]	F <sub>a</sub> [N]	F <sub>r</sub> [N]	F <sub>a</sub> [N]	F <sub>r</sub> [N]	F <sub>a</sub> [N]
< 12	180	90	250	125	300	150	350	175	450	225	550	275
> 12	150	75	210	105	250	125	290	145	380	190	460	230

## Zulässige Radialkraft F<sub>r2</sub> und Axialkraft F<sub>a2</sub> an der Welle N<sub>2</sub>

n <sub>2</sub> [1/min]	3000		1000		500		250		100		50	
T <sub>2</sub> [Nm]	F <sub>r</sub> [N]	F <sub>a</sub> [N]	F <sub>r</sub> [N]	F <sub>a</sub> [N]	F <sub>r</sub> [N]	F <sub>a</sub> [N]	F <sub>r</sub> [N]	F <sub>a</sub> [N]	F <sub>r</sub> [N]	F <sub>a</sub> [N]	F <sub>r</sub> [N]	F <sub>a</sub> [N]
< 12	300	150	400	200	500	250	650	325	750	375	900	450
> 12	250	125	330	165	420	210	540	270	630	315	750	375

## Massenträgheitsmomente / Masse

Massenträgheitsmoment J<sub>1</sub> auf die schnell-laufende Welle (N<sub>1</sub>) bezogen

Bauart	Massenträgheitsmoment [kgcm <sup>2</sup> ]							Masse [kg]
	1:1	1,5:1	2:1	3:1	4:1	5:1	6:1	
A0	0,38880	0,24060	0,18390	0,10360				2,3
B0	0,42310	0,31110	0,23300	0,10010				2,2
C0	0,42310	0,31110	0,23300	0,10010				2,2
D0	0,43300	0,31550	0,23550	0,10120				2,3
E0N	0,47540	0,36340	0,28530	0,15240				2,1
E0S	0,60120	0,48920	0,41110	0,27820				2,1
F0	0,58320	0,32700	0,23250	0,12520				2,7
G0	0,61750	0,46530	0,36830	0,18210				2,6
H0	0,61750	0,46530	0,36830	0,18210				2,6
J0	0,62740	0,46970	0,37080	0,18320				2,7
K0N	0,66980	0,51760	0,42060	0,23440				2,5
K0S	0,79560	0,64340	0,54640	0,36020				2,5

Bauart

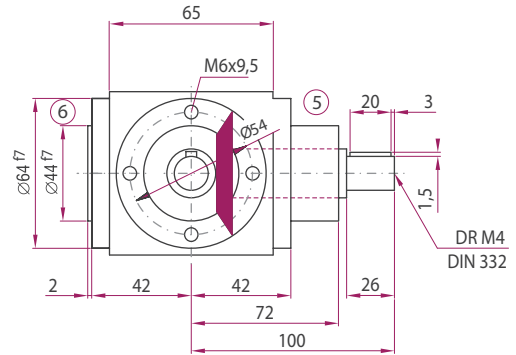
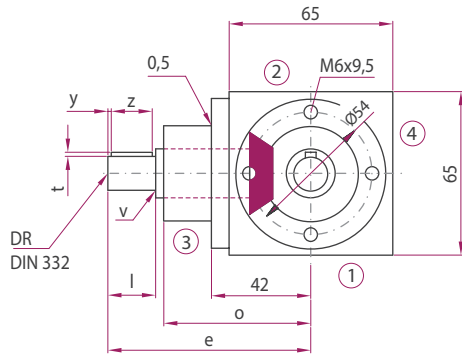
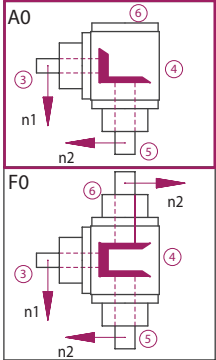

Bauart

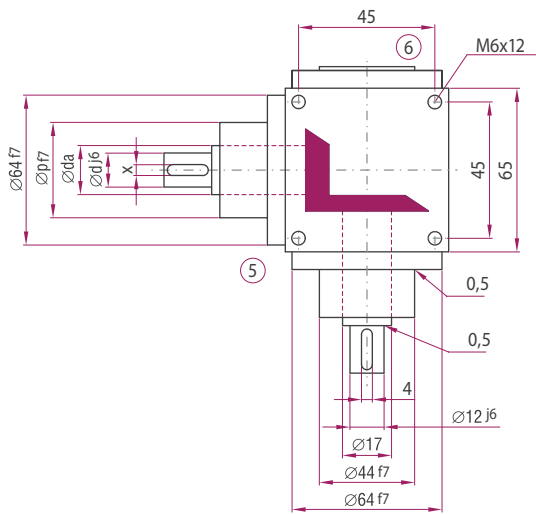
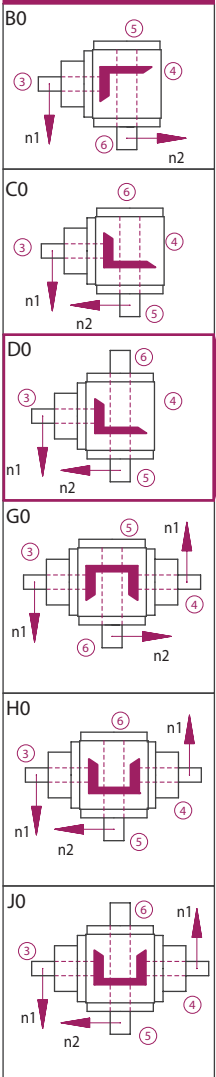

	Übersetzung						
	1:1	1,5:1	2:1	3:1	4:1	5:1	6:1
d [mm]	12	12	12	12			
da [mm]	17	17	17	17			
l [mm]	26	26	26	26			
v [mm]	0,5	0,5	0,5	0,5			
x [mm]	4	4	4	4			
y [mm]	3	3	3	3			
z [mm]	20	20	20	20			
t [mm]	1,5	1,5	1,5	1,5			
e [mm]	100	100	100	100			
o [mm]	72	72	72	72			
p [mm]	44	44	44	44			
DR M	4	4	4	4			

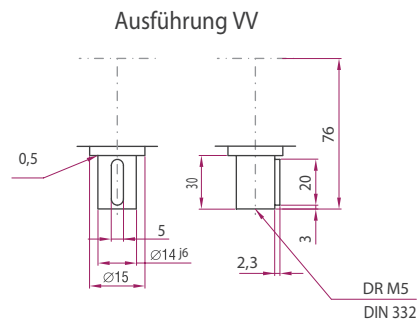
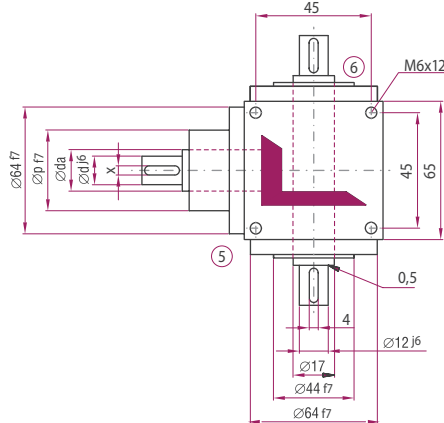
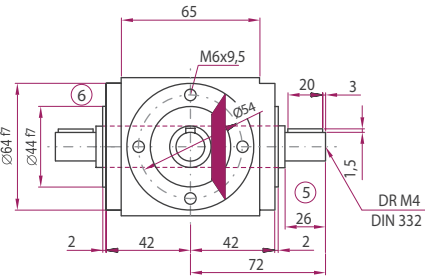
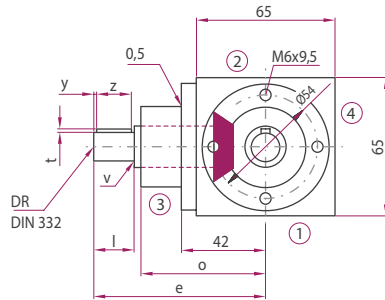



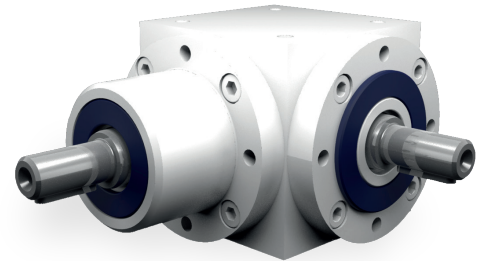

### Eigenschaften

Eigenschaft	Standard
Verzahnung	Kegelradsatz, spiralverzahnt
Gehäuse / Flansche	Grauguss; Stahl
Befestigungs-Gewindebohrung	An allen Gehäuseflächen ohne Flansch und an allen Flanschen.
Welle	Werkstoff 1 C 45, Wellenenden gefettet Passung mit der Toleranz ISO 6 mit Passfedernut: nach DIN 6885 Blatt 1
Hohlwelle	Werkstoff 1 C 45, Wellenenden gefettet Passung mit der Toleranz ISO 7 mit Passfedernut nach DIN 6885 Blatt 1
Radial- Wellendichtring	NBR Form A
Umgebungstemperatur	- 10°C bis + 90°C. Die Werte der Leistungstabellen gelten für + 20°C
Verdreh-Flankenspiel	< 30 arcmin
Schutzklasse	IP 31
Korrosionsschutz	Grundierung; Schichtdicke > 40 µm
Lagerlebensdauer L10h	größer als 15.000 h
Ölwechselintervalle	Bei Einhaltung der Öltemperatur von < 90°C nicht erforderlich Die Lebensdauer der Lager kann um den Faktor 1,5 gesteigert werden, wenn nach den ersten 500 Betriebsstunden und dann alle 5000 Betriebsstunden ein Ölwechsel erfolgt.
Schmierstoff	Synthetische Schmierstoffe

## Leistungsdaten

n <sub>1</sub> [1/min]	1:1			1,5:1			2:1			3:1			4:1			5:1			6:1			
	n <sub>2</sub> [1/min]	P <sub>1N</sub> [kW]	T <sub>2N</sub> [Nm]	n <sub>2</sub> [1/min]	P <sub>1N</sub> [kW]	T <sub>2N</sub> [Nm]	n <sub>2</sub> [1/min]	P <sub>1N</sub> [kW]	T <sub>2N</sub> [Nm]	n <sub>2</sub> [1/min]	P <sub>1N</sub> [kW]	T <sub>2N</sub> [Nm]	n <sub>2</sub> [1/min]	P <sub>1N</sub> [kW]	T <sub>2N</sub> [Nm]	n <sub>2</sub> [1/min]	P <sub>1N</sub> [kW]	T <sub>2N</sub> [Nm]	n <sub>2</sub> [1/min]	P <sub>1N</sub> [kW]	T <sub>2N</sub> [Nm]	
3000	3000	8,93	27	2000	5,51	25	1500	3,80	23	1000	2,54	23	750	1,90	23	600	1,52	23	500	1,25	23	
2400	2400	7,41	28	1600	4,59	26	1200	3,17	24	800	2,12	24	600	1,65	25	480	1,32	25	400	1,09	25	
1500	1500	5,29	32	1000	3,20	29	750	2,23	27	500	1,49	27	375	1,12	27	300	0,89	27	250	0,74	27	
1000	1000	3,75	34	667	2,35	32	500	1,71	31	333	1,14	31	250	0,85	31	200	0,68	31	167	0,53	29	
750	750	3,06	37	500	1,93	35	375	1,32	32	250	0,88	32	188	0,66	32	150	0,53	32	125	0,40	29	
500	500	2,20	40	333	1,36	37	250	0,94	34	167	0,63	34	125	0,47	34	100	0,37	34	83	0,27	29	
250	250	1,21	44	167	0,74	40	125	0,50	36	83	0,33	36	63	0,25	36	50	0,20	36	42	0,14	30	
50	50	0,28	50	33	0,16	45	25	0,10	37	17	0,07	37	13	0,05	37	10	0,04	37	8	0,03	33	
P <sub>1Nt</sub> [kW]		3,8			3,8			3,8			3,8			3,8			3,8			3,8		
T <sub>2max</sub> [Nm]		105			45			80			70			70			60			50		

## Zulässige Radialkraft F<sub>r1</sub> und Axialkraft F<sub>a1</sub> an der Welle N<sub>1</sub>

n <sub>1</sub> [1/min]	3000		1000		500		250		100		50	
T <sub>2</sub> [Nm]	F <sub>r</sub> [N]	F <sub>a</sub> [N]	F <sub>r</sub> [N]	F <sub>a</sub> [N]	F <sub>r</sub> [N]	F <sub>a</sub> [N]	F <sub>r</sub> [N]	F <sub>a</sub> [N]	F <sub>r</sub> [N]	F <sub>a</sub> [N]	F <sub>r</sub> [N]	F <sub>a</sub> [N]
< 30	300	150	400	200	470	235	580	290	700	350	800	400
> 30	250	125	330	165	390	195	490	245	590	295	670	335

## Zulässige Radialkraft F<sub>r2</sub> und Axialkraft F<sub>a2</sub> an der Welle N<sub>2</sub>

n <sub>2</sub> [1/min]	3000		1000		500		250		100		50	
T <sub>2</sub> [Nm]	F <sub>r</sub> [N]	F <sub>a</sub> [N]	F <sub>r</sub> [N]	F <sub>a</sub> [N]	F <sub>r</sub> [N]	F <sub>a</sub> [N]	F <sub>r</sub> [N]	F <sub>a</sub> [N]	F <sub>r</sub> [N]	F <sub>a</sub> [N]	F <sub>r</sub> [N]	F <sub>a</sub> [N]
< 30	500	250	660	330	800	400	950	475	1250	625	1500	750
> 30	420	210	550	275	670	335	790	395	1040	520	1250	625

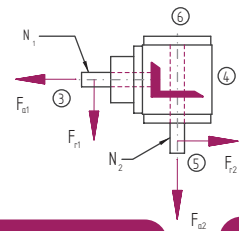

## Massenträgheitsmomente / Masse

Massenträgheitsmoment J<sub>1</sub> auf die schnell-laufende Welle (N<sub>1</sub>) bezogen

Bauart	Massenträgheitsmoment [kgcm <sup>2</sup> ]							Masse [kg]
	1:1	1,5:1	2:1	3:1	4:1	5:1	6:1	
A0	2,55900	1,48220	1,14370	0,88840	0,36310	0,32480	0,30620	5,1
B0	3,35430	2,18330	1,36520	1,04650	0,46070	0,39330	0,35020	5,4
C0	3,35430	2,18330	1,36520	1,04650	0,46070	0,39330	0,35020	5,4
D0	3,38270	2,19590	1,37230	1,04960	0,46250	0,39450	0,35100	5,5
E0N	3,25070	2,13720	1,33930	1,03500	0,45420	0,38920	0,34730	5,0
E0S	3,92130	2,43530	1,50690	1,10950	0,49610	0,41600	0,36600	5,2
F0	3,83850	2,05080	1,46360	1,03050	0,44300	0,37600	0,34180	6,3
G0	4,63380	3,09680	2,18900	1,79270	0,74380	0,66690	0,62090	6,9
H0	4,63380	3,09680	2,18900	1,79270	0,74380	0,66690	0,62090	6,9
J0	4,66220	3,10940	2,19610	1,79580	0,74560	0,66810	0,62170	7,0
K0N	4,53020	3,05070	2,16310	1,78120	0,73730	0,66280	0,61800	6,5
K0S	5,20080	3,34880	2,33070	1,85570	0,77920	0,68960	0,63670	6,7

**Bauart**

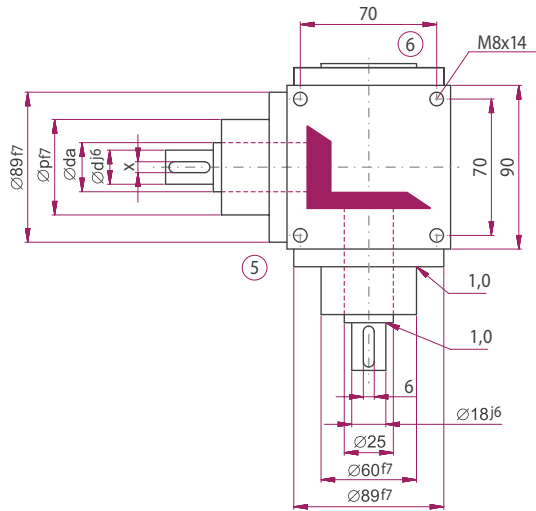
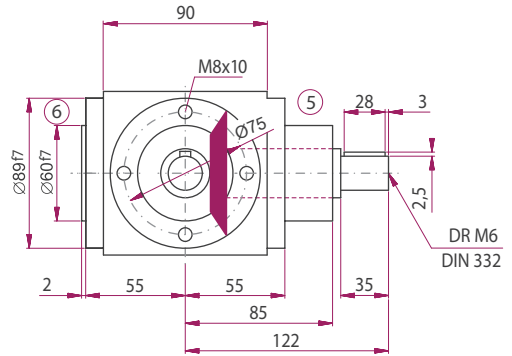
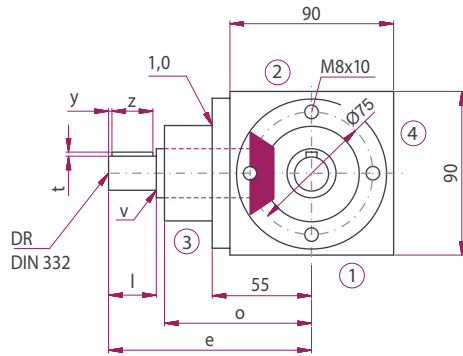
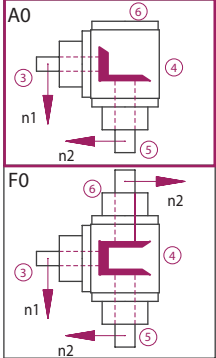

	Übersetzung						
	1:1	1,5:1	2:1	3:1	4:1	5:1	6:1
d [mm]	18	18	18	12	12	12	12
da [mm]	25	25	25	20	20	20	20
l [mm]	35	35	35	35	35	35	35
v [mm]	1	1	1	0,5	0,5	0,5	0,5
x [mm]	6	6	6	4	4	4	4
y [mm]	3	3	3	3	3	3	3
z [mm]	28	28	28	28	28	28	28
t [mm]	2,5	2,5	2,5	1,5	1,5	1,5	1,5
e [mm]	122	122	122	122	132	132	132
o [mm]	85	85	85	85	95	95	95
p [mm]	60	60	60	60	60	60	60
DR M	6	6	6	4	4	4	4

**Bauart**

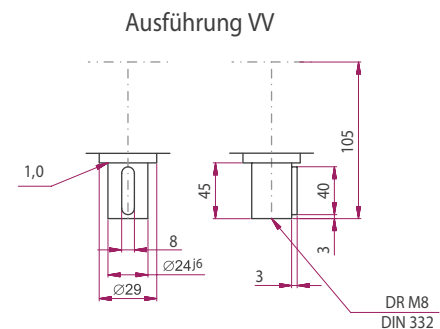
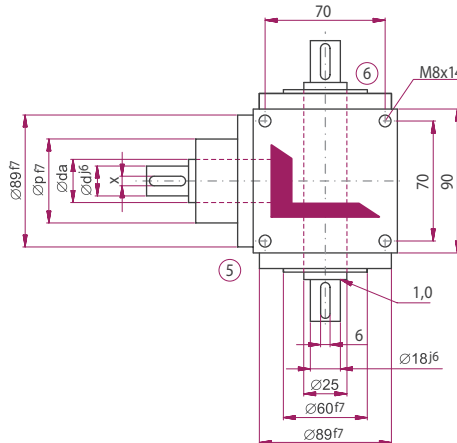
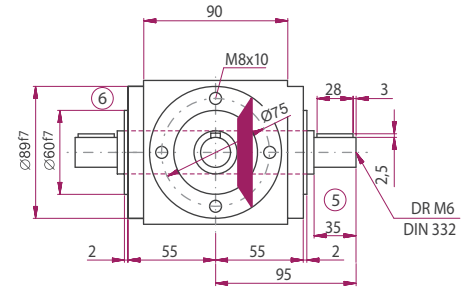
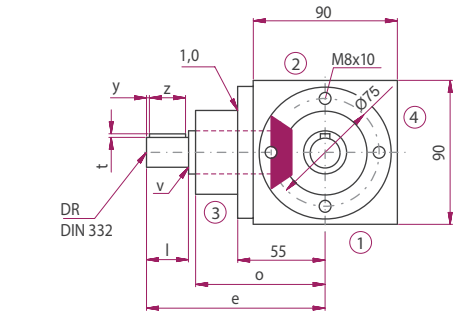
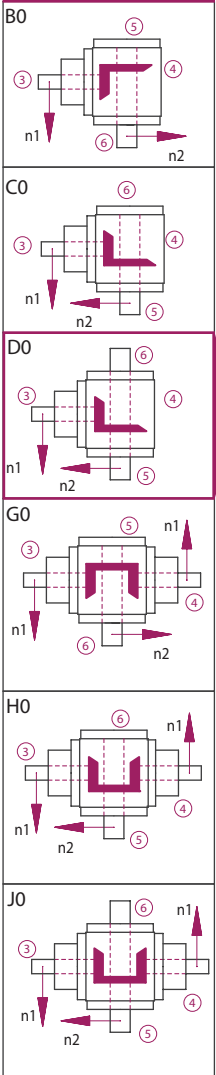

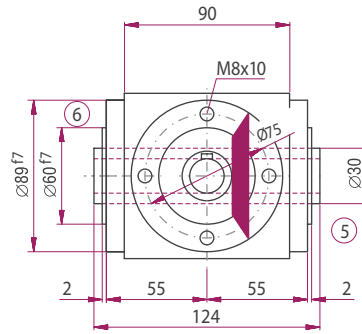
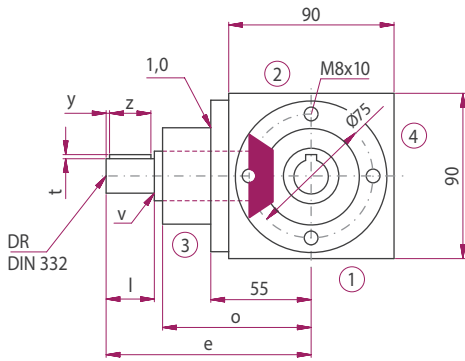

Ausführungen

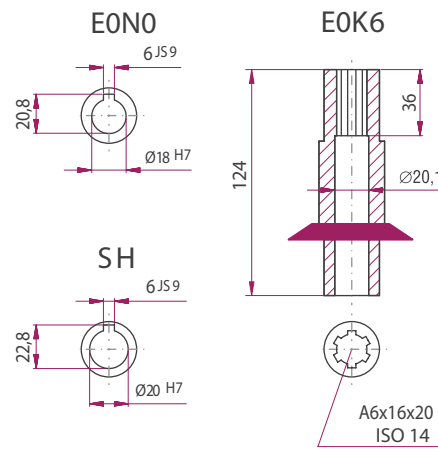
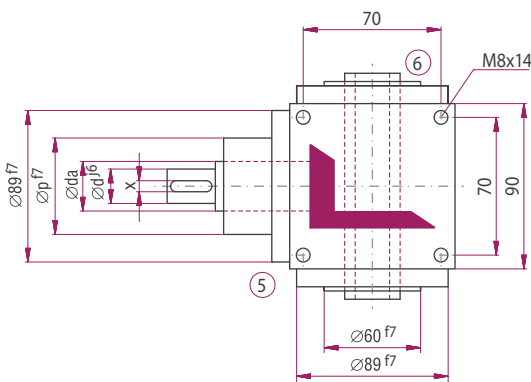

Bauart

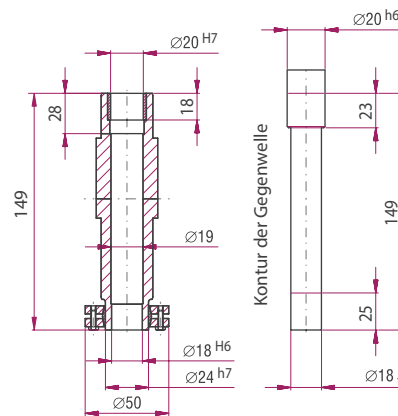
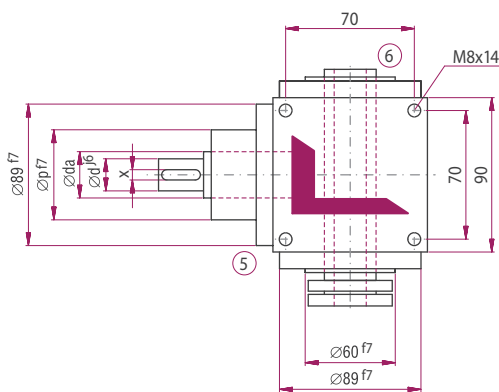
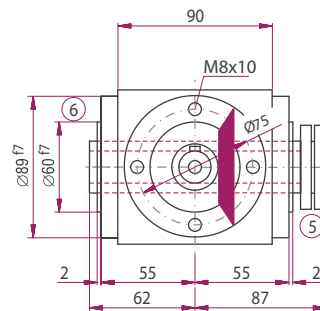
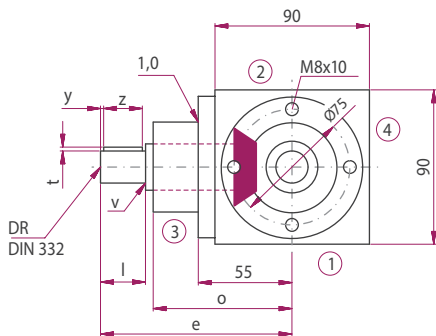
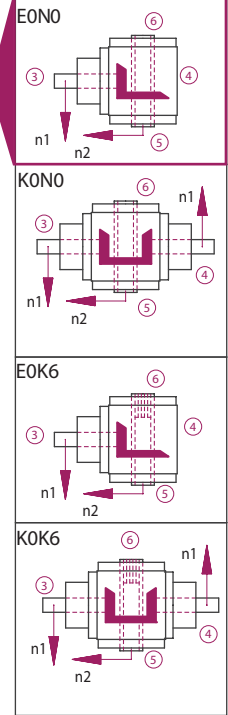

Bauart

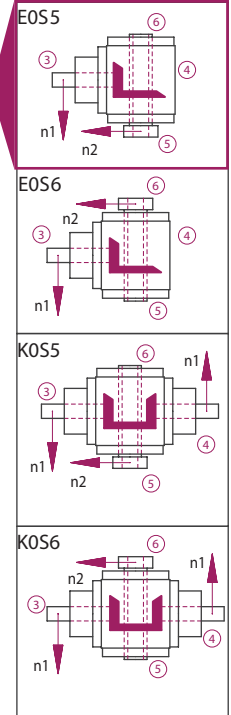

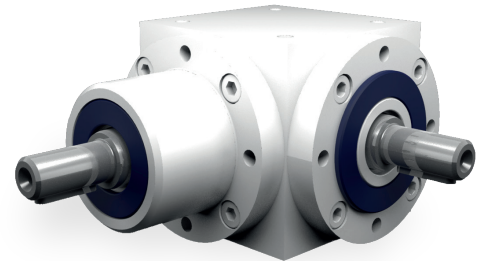

## Eigenschaften

Eigenschaft	Standard
Verzahnung	Kegelradsatz, spiralverzahnt
Gehäuse / Flansche	Grauguss; Stahl
Befestigungs-Gewindebohrung	An allen Gehäuseflächen ohne Flansch und an allen Flanschen.
Welle	Werkstoff 1 C 45, Wellenenden gefettet Passung mit der Toleranz ISO 6 mit Passfedernut: nach DIN 6885 Blatt 1
Hohlwelle	Werkstoff 1 C 45, Wellenenden gefettet Passung mit der Toleranz ISO 7 mit Passfedernut nach DIN 6885 Blatt 1
Radial- Wellendichtring	NBR Form A
Umgebungstemperatur	- 10°C bis + 90°C. Die Werte der Leistungstabellen gelten für + 20°C
Verdreh-Flankenspiel	< 30 arcmin
Schutzklasse	IP 31
Korrosionsschutz	Grundierung; Schichtdicke > 40 µm
Lagerlebensdauer L10h	größer als 15.000h
Ölwechselintervalle	Bei Einhaltung der Öltemperatur von < 90°C nicht erforderlich Die Lebensdauer der Lager kann um den Faktor 1,5 gesteigert werden, wenn nach den ersten 500 Betriebsstunden und dann alle 5000 Betriebsstunden ein Ölwechsel erfolgt.
Schmierstoff	Synthetische Schmierstoffe

## Leistungsdaten

n <sub>1</sub> [1/min]	1:1		1,5:1			2:1			3:1			4:1			5:1			6:1				
	n <sub>2</sub> [1/min]	P <sub>1N</sub> [kW]	T <sub>2N</sub> [Nm]	n <sub>2</sub> [1/min]	P <sub>1N</sub> [kW]	T <sub>2N</sub> [Nm]	n <sub>2</sub> [1/min]	P <sub>1N</sub> [kW]	T <sub>2N</sub> [Nm]	n <sub>2</sub> [1/min]	P <sub>1N</sub> [kW]	T <sub>2N</sub> [Nm]	n <sub>2</sub> [1/min]	P <sub>1N</sub> [kW]	T <sub>2N</sub> [Nm]	n <sub>2</sub> [1/min]	P <sub>1N</sub> [kW]	T <sub>2N</sub> [Nm]	n <sub>2</sub> [1/min]	P <sub>1N</sub> [kW]	T <sub>2N</sub> [Nm]	
3000	3000	21,82	66	2000	13,45	61	1500	9,26	56	1000	6,39	58	750	4,96	60	600	3,97	60	500	2,95	54	
2400	2400	18,52	70	1600	11,46	65	1200	8,07	61	800	5,56	63	600	4,43	67	480	3,44	65	400	2,53	57	
1500	1500	13,56	82	1000	8,60	78	750	6,03	73	500	4,08	74	375	3,06	74	300	2,38	72	250	1,75	64	
1000	1000	10,14	92	667	6,32	86	500	4,46	81	333	3,01	82	250	2,18	79	200	1,76	80	167	1,22	66	
750	750	8,51	103	500	5,18	94	375	3,55	86	250	2,40	87	188	1,69	82	150	1,42	86	125	0,94	68	
500	500	6,34	115	333	3,85	100	250	2,54	92	167	1,66	90	125	1,16	84	100	0,98	89	83	0,63	69	
250	250	3,39	123	167	1,99	100	125	1,35	98	83	0,87	95	63	0,60	87	50	0,51	92	42	0,33	71	
50	50	0,72	130	33	0,41	100	25	0,29	107	17	0,21	110	13	0,12	90	10	0,10	95	8	0,06	66	
P <sub>1Nt</sub> [kW]	6,2			6,2				6,2				6,2				6,2				6,2		
T <sub>2max</sub> [Nm]	220			100				169				155				140				120		

## Zulässige Radialkraft F<sub>r1</sub> und Axialkraft F<sub>a1</sub> an der Welle N<sub>1</sub>

n <sub>1</sub> [1/min]	3000		1000		500		250		100		50	
T <sub>2</sub> [Nm]	F <sub>r</sub> [N]	F <sub>a</sub> [N]	F <sub>r</sub> [N]	F <sub>a</sub> [N]	F <sub>r</sub> [N]	F <sub>a</sub> [N]	F <sub>r</sub> [N]	F <sub>a</sub> [N]	F <sub>r</sub> [N]	F <sub>a</sub> [N]	F <sub>r</sub> [N]	F <sub>a</sub> [N]
< 80	470	235	620	310	720	360	900	450	1150	575	1400	700
> 80	390	195	520	260	600	300	750	375	960	480	1170	585

## Zulässige Radialkraft F<sub>r2</sub> und Axialkraft F<sub>a2</sub> an der Welle N<sub>2</sub>

n <sub>2</sub> [1/min]	3000		1000		500		250		100		50	
T <sub>2</sub> [Nm]	F <sub>r</sub> [N]	F <sub>a</sub> [N]	F <sub>r</sub> [N]	F <sub>a</sub> [N]	F <sub>r</sub> [N]	F <sub>a</sub> [N]	F <sub>r</sub> [N]	F <sub>a</sub> [N]	F <sub>r</sub> [N]	F <sub>a</sub> [N]	F <sub>r</sub> [N]	F <sub>a</sub> [N]
< 80	750	375	1000	500	1250	625	1500	750	1900	950	2200	1100
> 80	630	315	830	415	1040	520	1250	625	1580	790	1830	915

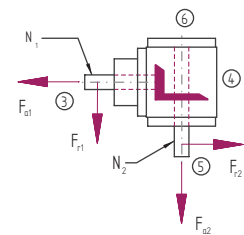

## Massenträgheitsmomente / Masse

Massenträgheitsmoment J<sub>1</sub> auf die schnell-laufende Welle (N<sub>1</sub>) bezogen

Bauart	Massenträgheitsmoment [kgm <sup>2</sup> ]							Masse [kg]
	1:1	1,5:1	2:1	3:1	4:1	5:1	6:1	
A0	10,4976	4,84090	3,64650	2,31590	1,21640	0,75160	0,67660	12,6
B0	15,3022	7,44410	4,97470	3,01230	1,67290	1,05930	0,89820	12,3
C0	15,3022	7,44410	4,97470	3,01230	1,67290	1,05930	0,89820	12,3
D0	15,5996	7,57620	5,04900	3,04530	1,69150	1,07120	0,90650	12,5
E0N	15,1939	7,39590	4,94760	3,00030	1,66610	1,05500	0,89520	12,0
E0S	16,9812	8,19030	5,39440	3,19880	1,77780	1,12650	0,94490	12,3
F0	15,7464	7,17370	4,95870	2,89910	1,54440	0,96150	0,82240	15,0
G0	20,5510	9,95220	7,30900	4,74500	2,56120	1,60090	1,42900	14,7
H0	20,5510	9,95220	7,30900	4,74500	2,56120	1,60090	1,42900	14,7
J0	20,8484	10,0843	7,38330	4,77800	2,57980	1,61280	1,43730	14,9
K0N	20,4427	9,90400	7,28190	4,73300	2,55440	1,59660	1,42600	14,4
K0S	22,2300	10,6984	7,72870	4,93150	2,66610	1,66810	1,47570	14,7

**Bauart**

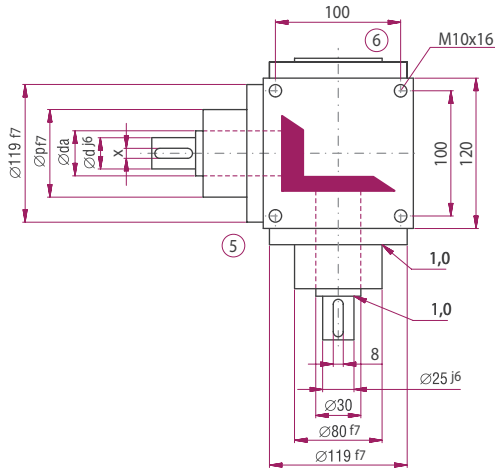
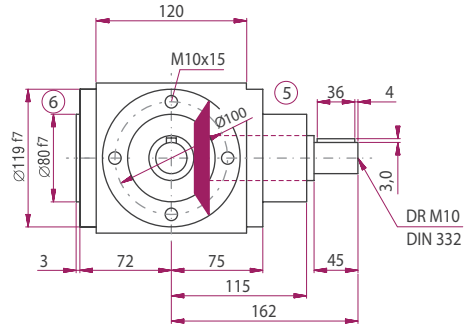
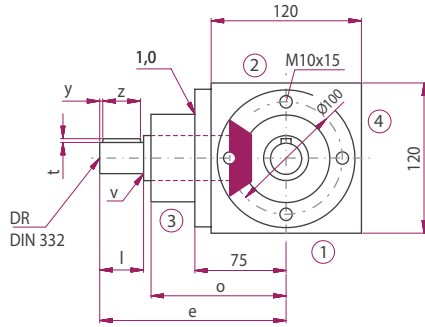
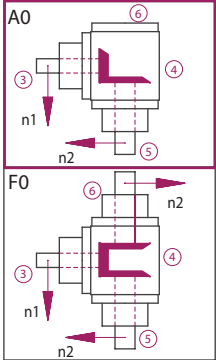

	Übersetzung						
	1:1	1,5:1	2:1	3:1	4:1	5:1	6:1
d [mm]	25	25	25	20	20	15	15
da [mm]	30	30	30	25	25	20	20
l [mm]	45	45	45	45	45	35	35
v [mm]	1	1	1	1	1	0,5	0,5
x [mm]	8	8	8	6	6	5	5
y [mm]	4	4	4	4	4	4	4
z [mm]	36	36	36	36	36	28	28
t [mm]	3	3	3	2,5	2,5	2	2
e [mm]	162	162	162	162	172	162	162
o [mm]	115	115	115	115	125	125	125
p [mm]	80	80	80	80	80	70	70
DR M	10	10	10	6	6	5	5

**Bauart**

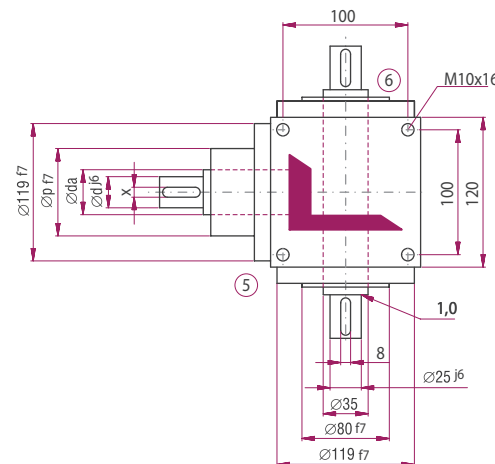
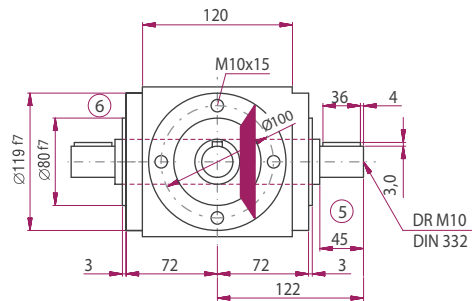
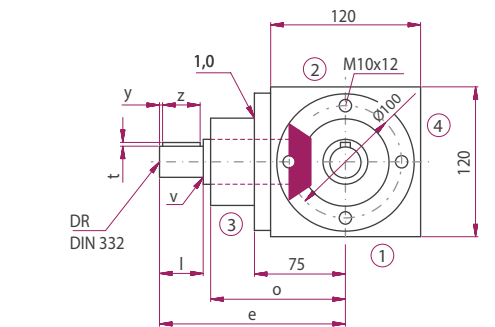
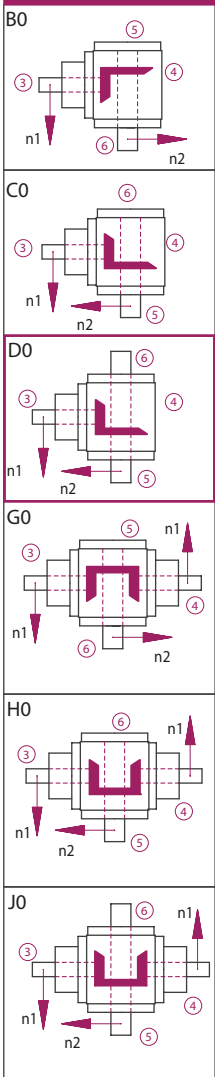

**Ausführung WV**

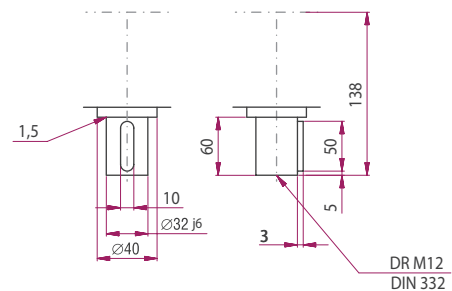

Die Maße der nicht dargestellten Bauarten ergeben sich durch die Spiegelung vorhandener Maße.

Produktkatalog 2024/2025 – Stand 2024-07-16

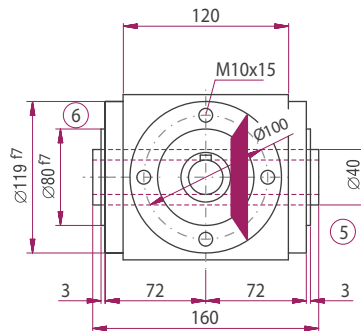
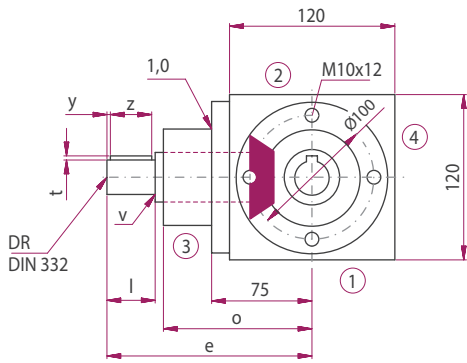

Ausführungen

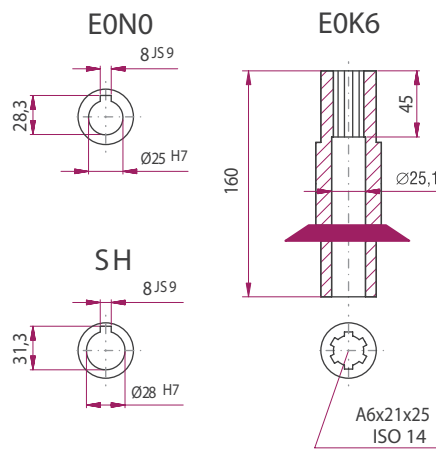
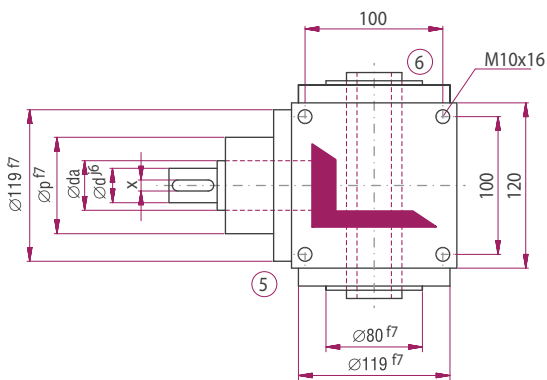

Bauart

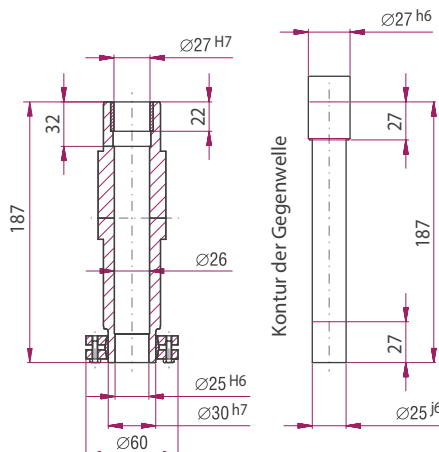
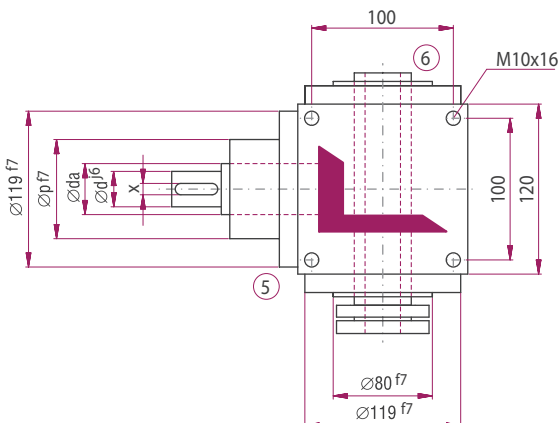
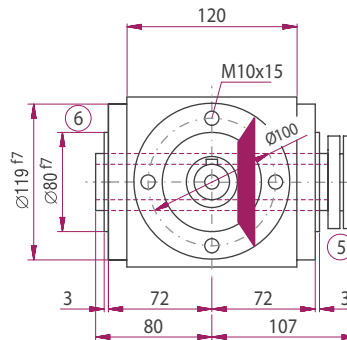
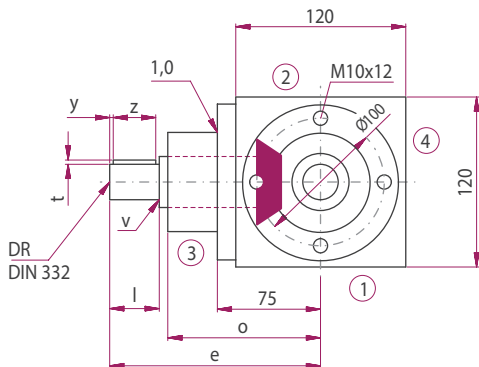
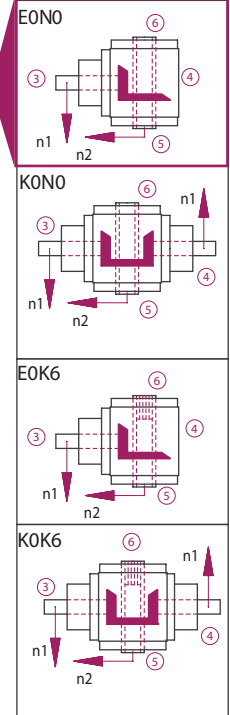

Bauart

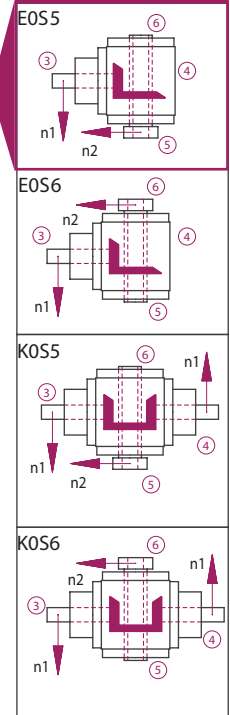

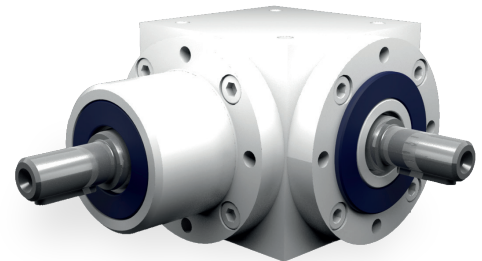

## Eigenschaften

Eigenschaft	Standard
Verzahnung	Kegelradsatz, spiralverzahnt
Gehäuse / Flansche	Grauguss; Stahl
Befestigungs-Gewindebohrung	An allen Gehäuseflächen ohne Flansch und an allen Flanschen.
Welle	Werkstoff 1 C 45, Wellenenden gefettet Passung mit der Toleranz ISO 6 mit Passfedernut: nach DIN 6885 Blatt 1
Hohlwelle	Werkstoff 1 C 45, Wellenenden gefettet Passung mit der Toleranz ISO 7 mit Passfedernut nach DIN 6885 Blatt 1
Radial- Wellendichtring	NBR Form A
Umgebungstemperatur	- 10°C bis + 90°C. Die Werte der Leistungstabellen gelten für + 20°C
Verdreh-Flankenspiel	< 30 arcmin
Schutzklasse	IP 31
Korrosionsschutz	Grundierung; Schichtdicke > 40 µm
Lagerlebensdauer L10h	größer als 15.000 h
Ölwechselintervalle	Bei Einhaltung der Öltemperatur von < 90°C nicht erforderlich Die Lebensdauer der Lager kann um den Faktor 1,5 gesteigert werden, wenn nach den ersten 500 Betriebsstunden und dann alle 5000 Betriebsstunden ein Ölwechsel erfolgt.
Schmierstoff	Synthetische Schmierstoffe

## Leistungsdaten

n <sub>1</sub> [1/min]	1:1				1,5:1			2:1			3:1			4:1			5:1			6:1		
	n <sub>2</sub> [1/min]	P <sub>1N</sub> [kW]	T <sub>2N</sub> [Nm]		n <sub>2</sub> [1/min]	P <sub>1N</sub> [kW]	T <sub>2N</sub> [Nm]	n <sub>2</sub> [1/min]	P <sub>1N</sub> [kW]	T <sub>2N</sub> [Nm]	n <sub>2</sub> [1/min]	P <sub>1N</sub> [kW]	T <sub>2N</sub> [Nm]	n <sub>2</sub> [1/min]	P <sub>1N</sub> [kW]	T <sub>2N</sub> [Nm]	n <sub>2</sub> [1/min]	P <sub>1N</sub> [kW]	T <sub>2N</sub> [Nm]	n <sub>2</sub> [1/min]	P <sub>1N</sub> [kW]	T <sub>2N</sub> [Nm]
3000	3000	39,68	120		2000	24,91	113	1500	16,53	100	1000	12,12	110	750	8,51	103	600	6,61	100	500	5,18	94
2400	2400	37,04	140		1600	22,22	126	1200	14,68	111	800	11,46	130	600	7,34	111	480	5,56	105	400	4,58	104
1500	1500	26,78	162		1000	17,08	155	750	11,41	138	500	8,05	146	375	4,96	120	300	3,80	115	250	2,95	107
1000	1000	20,28	184		667	12,87	175	500	8,38	152	333	5,87	160	250	3,75	136	200	2,73	124	167	2,06	112
750	750	16,20	196		500	10,47	190	375	6,86	166	250	4,60	167	188	3,06	148	150	2,15	130	125	1,61	117
500	500	11,46	208		333	7,34	200	250	4,96	180	167	3,20	174	125	2,12	154	100	1,50	136	83	1,09	119
250	250	5,92	215		167	3,76	204	125	2,62	190	83	1,62	177	63	1,12	162	50	0,79	143	42	0,56	121
50	50	1,21	220		33	0,76	210	25	0,55	200	17	0,34	180	13	0,23	170	10	0,17	150	8	0,11	120
P <sub>1Nt</sub> [kW]		10,0			10,0			10,0			10,0			10,0			10,0					
T <sub>2max</sub> [Nm]		430			210			320			280			280			250			200		

## Zulässige Radialkraft F<sub>r1</sub> und Axialkraft F<sub>a1</sub> an der Welle N<sub>1</sub>

n <sub>1</sub> [1/min]	3000		1000		500		250		100		50	
T <sub>2</sub> [Nm]	F <sub>r</sub> [N]	F <sub>a</sub> [N]	F <sub>r</sub> [N]	F <sub>a</sub> [N]	F <sub>r</sub> [N]	F <sub>a</sub> [N]	F <sub>r</sub> [N]	F <sub>a</sub> [N]	F <sub>r</sub> [N]	F <sub>a</sub> [N]	F <sub>r</sub> [N]	F <sub>a</sub> [N]
< 140	700	350	870	435	1150	575	1370	685	1700	850	2000	1000
> 140	590	295	730	365	960	480	1140	570	1420	710	1670	835

## Zulässige Radialkraft F<sub>r2</sub> und Axialkraft F<sub>a2</sub> an der Welle N<sub>2</sub>

n <sub>2</sub> [1/min]	3000		1000		500		250		100		50	
T <sub>2</sub> [Nm]	F <sub>r</sub> [N]	F <sub>a</sub> [N]	F <sub>r</sub> [N]	F <sub>a</sub> [N]	F <sub>r</sub> [N]	F <sub>a</sub> [N]	F <sub>r</sub> [N]	F <sub>a</sub> [N]	F <sub>r</sub> [N]	F <sub>a</sub> [N]	F <sub>r</sub> [N]	F <sub>a</sub> [N]
< 140	1300	650	1700	850	2000	1000	2500	1250	3000	1500	3800	1900
> 140	1082	541	1420	710	1670	835	2080	1040	2500	1250	3170	1585

## Massenträgheitsmomente / Masse

Massenträgheitsmoment J<sub>1</sub> auf die schnell-laufende Welle (N<sub>1</sub>) bezogen

Bauart	Massenträgheitsmoment [kgcm <sup>2</sup> ]							Masse [kg]
	1:1	1,5:1	2:1	3:1	4:1	5:1	6:1	
A0	26,2670	11,8569	8,6762	6,43560	1,84320	1,53200	1,37080	19,0
B0	36,0994	18,7513	12,2785	7,95470	2,69780	2,21130	1,84260	18,5
C0	36,0994	18,7513	12,2785	7,95470	2,69780	2,21130	1,84260	18,5
D0	37,0815	19,1878	12,5241	8,06390	2,75920	2,25060	1,86980	19,0
E0N	32,6630	17,2240	11,4194	7,57290	2,48300	2,07390	1,74710	18,0
E0S	39,0643	20,0691	13,0198	8,28420	2,88310	2,32990	1,92490	18,7
F0	39,4005	17,6940	11,9596	7,89490	2,66410	2,05740	1,73560	23,0
G0	49,2329	24,7711	17,6713	12,9310	3,72020	3,21800	2,84860	22,7
H0	49,2329	24,7711	17,6713	12,9310	3,72020	3,21800	2,84860	22,7
J0	50,2150	25,2076	17,9169	13,0402	3,78160	3,25730	2,87580	23,2
K0N	45,7965	23,2438	16,8122	12,5492	3,50540	3,08060	2,75310	22,2
K0S	52,1978	26,0889	18,4126	13,2605	3,90550	3,33660	2,93090	22,9

Bauart

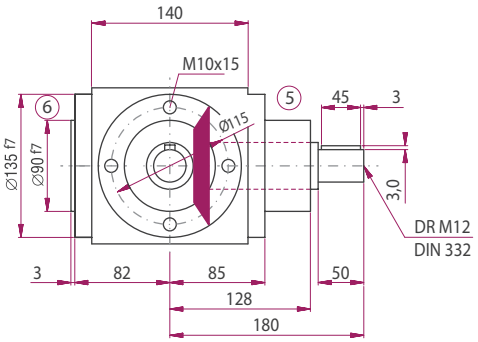
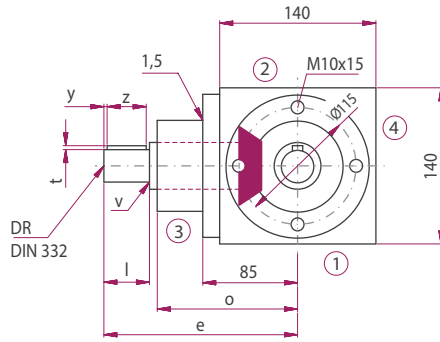
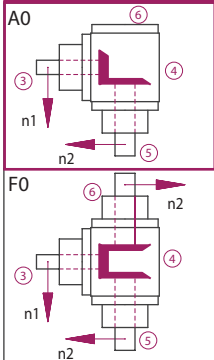

Bauart

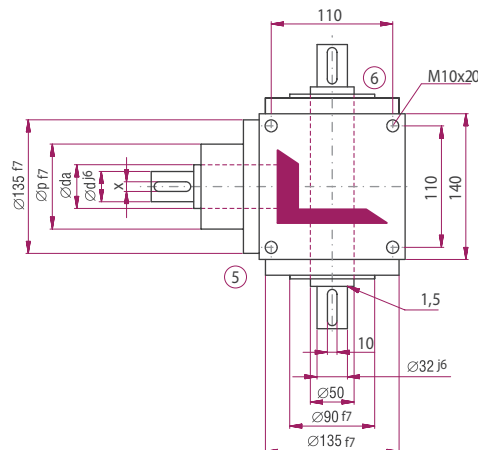
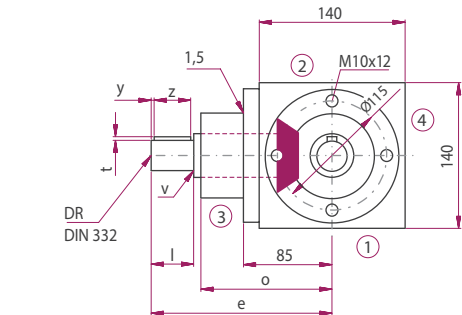
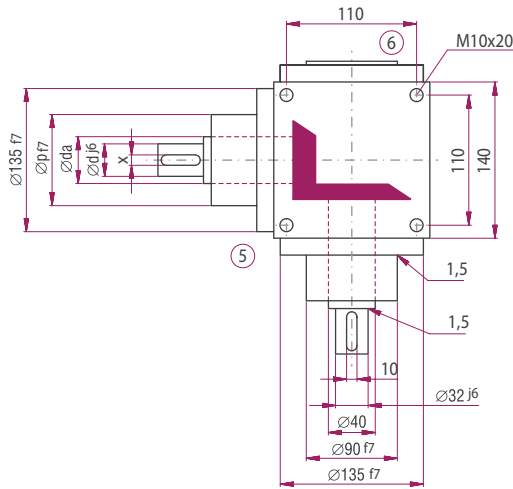
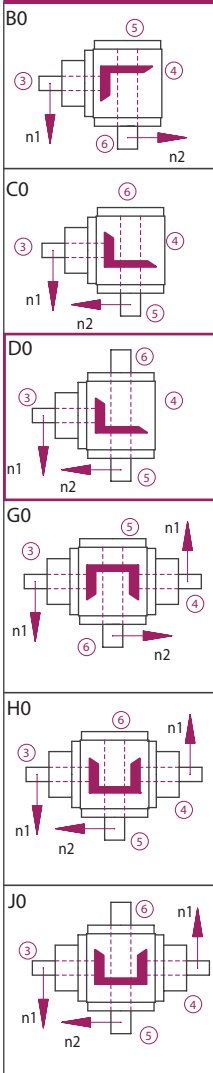

	Übersetzung						
	1:1	1,5:1	2:1	3:1	4:1	5:1	6:1
d [mm]	32	32	32	28	24	24	24
da [mm]	40	40	40	40	40	40	40
l [mm]	50	50	50	50	50	50	50
v [mm]	1,5	1,5	1,5	1	1	1	1
x [mm]	10	10	10	8	8	8	8
y [mm]	3	3	3	3	3	3	3
z [mm]	45	45	45	45	45	45	45
t [mm]	3	3	3	3	3	3	3
e [mm]	180	180	180	180	195	195	195
o [mm]	128	128	128	128	143	143	143
p [mm]	90	90	90	90	85	85	85
DR M	12	12	12	10	8	8	8

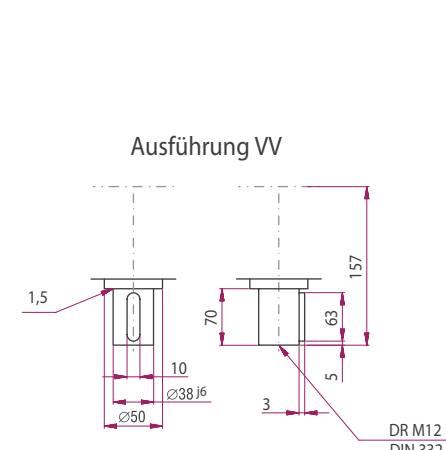
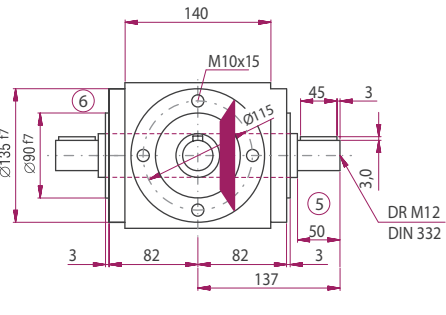

Ausführung WV

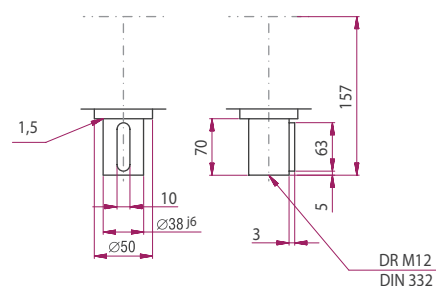

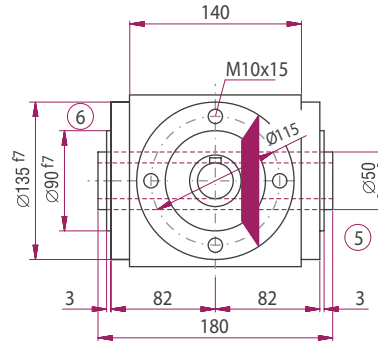
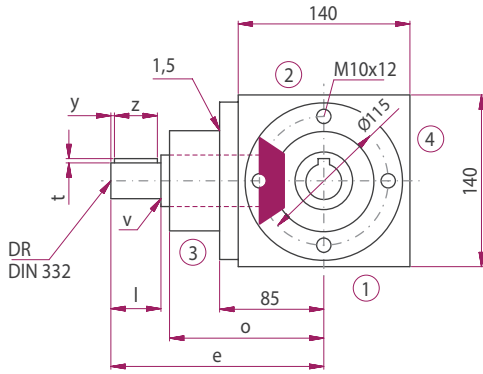

Ausführungen

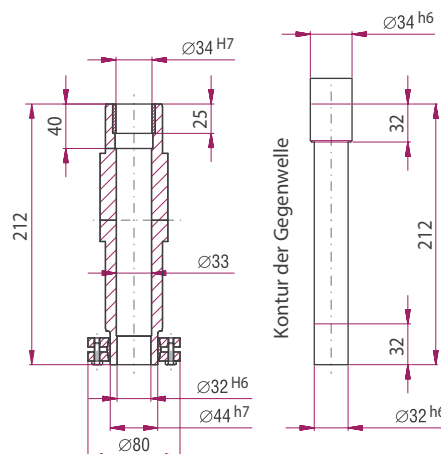
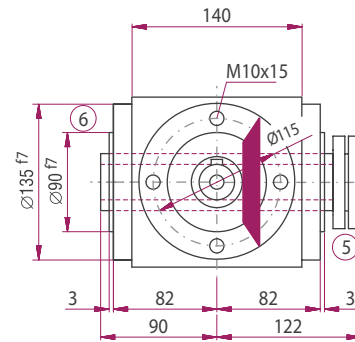
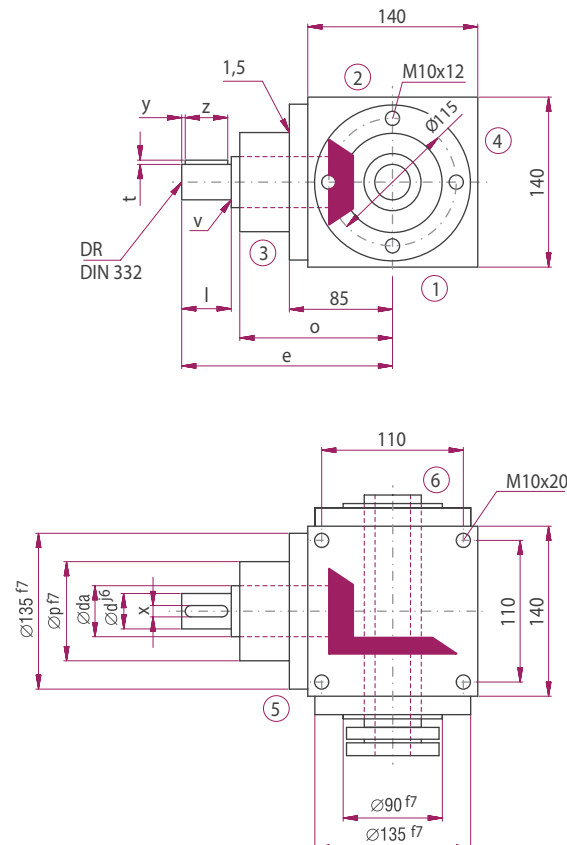
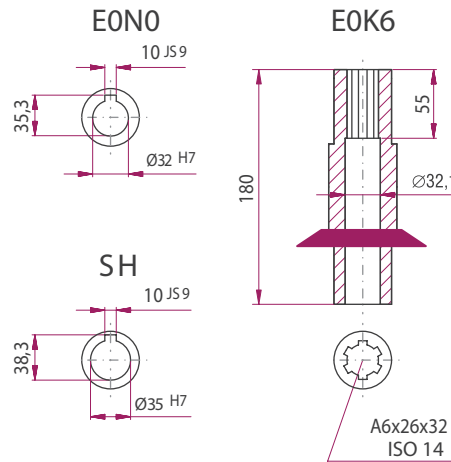
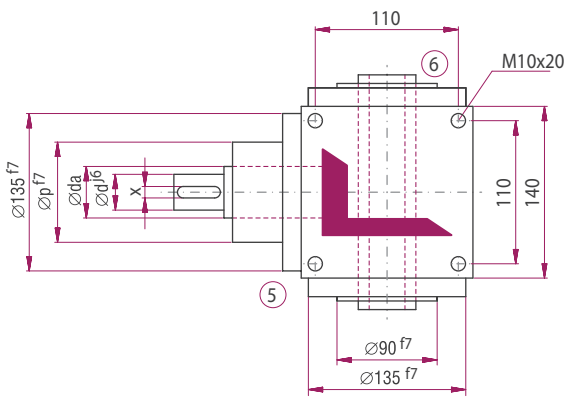

Bauart

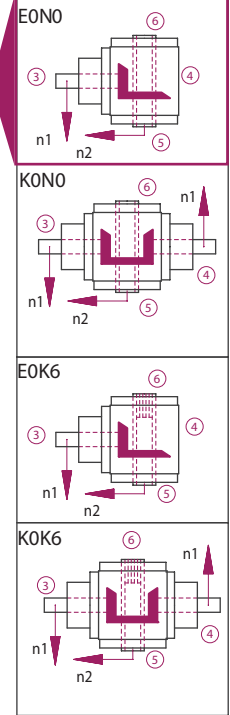

Bauart

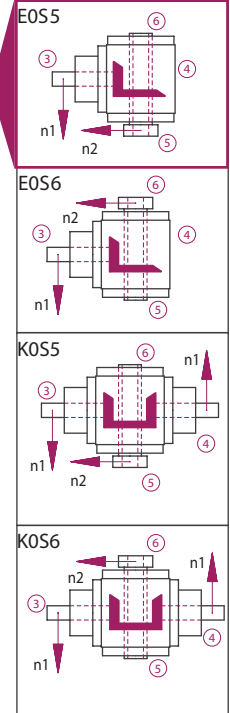

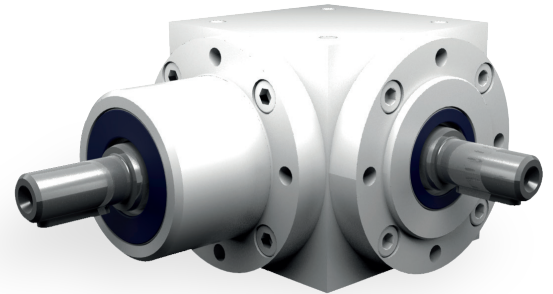

## Eigenschaften

Eigenschaft	Standard
Verzahnung	Kegelradsatz, spiralverzahnt
Gehäuse / Flansche	Grauguss; Stahl
Befestigungs-Gewindebohrung	An allen Gehäuseflächen ohne Flansch und an allen Flanschen.
Welle	Werkstoff 1 C 45, Wellenenden gefettet Passung mit der Toleranz ISO 6 mit Passfedernut: nach DIN 6885 Blatt 1
Hohlwelle	Werkstoff 1 C 45, Wellenenden gefettet Passung mit der Toleranz ISO 7 mit Passfedernut nach DIN 6885 Blatt 1
Radial- Wellendichtring	NBR Form A
Umgebungstemperatur	- 10°C bis + 90°C. Die Werte der Leistungstabellen gelten für + 20°C
Verdreh-Flankenspiel	< 30 arcmin
Schutzklasse	IP 31
Korrosionsschutz	Grundierung; Schichtdicke > 40 µm
Lagerlebensdauer L10h	größer als 15.000 h
Ölwechselintervalle	Bei Einhaltung der Öltemperatur von < 90°C nicht erforderlich Die Lebensdauer der Lager kann um den Faktor 1,5 gesteigert werden, wenn nach den ersten 500 Betriebsstunden und dann alle 5000 Betriebsstunden ein Ölwechsel erfolgt.
Schmierstoff	Synthetische Schmierstoffe

## Leistungsdaten

n <sub>1</sub> [1/min]	1:1			1,5:1			2:1			3:1			4:1			5:1			6:1					
	n <sub>2</sub> [1/min]	P <sub>1N</sub> [kW]	T <sub>2N</sub> [Nm]	n <sub>2</sub> [1/min]	P <sub>1N</sub> [kW]	T <sub>2N</sub> [Nm]	n <sub>2</sub> [1/min]	P <sub>1N</sub> [kW]	T <sub>2N</sub> [Nm]	n <sub>2</sub> [1/min]	P <sub>1N</sub> [kW]	T <sub>2N</sub> [Nm]	n <sub>2</sub> [1/min]	P <sub>1N</sub> [kW]	T <sub>2N</sub> [Nm]	n <sub>2</sub> [1/min]	P <sub>1N</sub> [kW]	T <sub>2N</sub> [Nm]	n <sub>2</sub> [1/min]	P <sub>1N</sub> [kW]	T <sub>2N</sub> [Nm]			
3000				2000	40,78	185	1500	28,11	170	1000	20,94	190	750	14,88	180	600	11,90	180	500	7,09	129			
2400	2400	57,67	218	1600	36,15	205	1200	25,53	193	800	17,81	202	600	13,23	200	480	10,48	198	400	5,98	136			
1500	1500	42,99	260	1000	27,78	252	750	20,25	245	500	12,68	230	375	9,09	220	300	7,11	215	250	3,95	143			
1000	1000	31,96	290	667	20,59	280	500	14,88	270	333	8,99	245	250	6,61	240	200	4,96	225	167	3,01	164			
750	750	25,63	310	500	16,26	295	375	11,57	280	250	6,89	250	188	5,17	250	150	3,97	240	125	2,43	176			
500	500	18,19	330	333	11,56	315	250	8,27	300	167	4,79	260	125	3,58	260	100	2,76	250	83	1,72	187			
250	250	9,64	350	167	6,07	330	125	4,41	320	83	2,56	280	63	1,86	270	50	1,49	270	42	0,92	199			
50	50	2,09	380	33	1,29	355	25	0,98	355	17	0,57	305	13	0,39	280	10	0,32	290	8	0,18	197			
P <sub>1Nt</sub> [kW]	15,0			15,0			15,0			15,0			15,0			15,0			15,0					
T <sub>2max</sub> [Nm]	660			650			650			457			422			420			350					

## Zulässige Radialkraft F<sub>r1</sub> und Axialkraft F<sub>a1</sub> an der Welle N<sub>1</sub>

n <sub>1</sub> [1/min]	3000		1000		500		250		100		50	
T <sub>2</sub> [Nm]	F <sub>r</sub> [N]	F <sub>a</sub> [N]	F <sub>r</sub> [N]	F <sub>a</sub> [N]	F <sub>r</sub> [N]	F <sub>a</sub> [N]	F <sub>r</sub> [N]	F <sub>a</sub> [N]	F <sub>r</sub> [N]	F <sub>a</sub> [N]	F <sub>r</sub> [N]	F <sub>a</sub> [N]
< 220	1200	600	1600	800	1900	950	2200	1100	2850	1425	3300	1650
> 220	1000	500	1340	670	1590	795	1840	920	2380	1190	2750	1375

## Zulässige Radialkraft F<sub>r2</sub> und Axialkraft F<sub>a2</sub> an der Welle N<sub>2</sub>

n <sub>2</sub> [1/min]	3000		1000		500		250		100		50	
T <sub>2</sub> [Nm]	F <sub>r</sub> [N]	F <sub>a</sub> [N]	F <sub>r</sub> [N]	F <sub>a</sub> [N]	F <sub>r</sub> [N]	F <sub>a</sub> [N]	F <sub>r</sub> [N]	F <sub>a</sub> [N]	F <sub>r</sub> [N]	F <sub>a</sub> [N]	F <sub>r</sub> [N]	F <sub>a</sub> [N]
< 220	2000	1000	2800	1400	3300	1650	4000	2000	5000	2500	6500	3250
> 220	1670	835	2340	1170	2750	1375	3340	1670	4170	2085	5420	2710

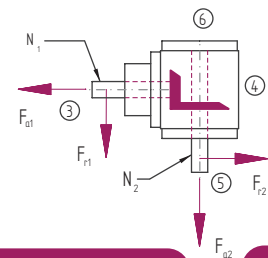

## Massenträgheitsmomente / Masse

Massenträgheitsmoment J<sub>1</sub> auf die schnell-laufende Welle (N<sub>1</sub>) bezogen

Bauart	Massenträgheitsmoment [kgcm <sup>2</sup> ]							Masse [kg]
	1:1	1,5:1	2:1	3:1	4:1	5:1	6:1	
A0	29,6710	19,6374	12,3589	8,9516	6,4348	2,2733	2,0901	28,5
B0	31,5527	32,0243	20,1006	12,0803	8,4198	3,6887	2,9407	28,0
C0	31,5527	32,0243	20,1006	12,0803	8,4198	3,6887	2,9407	28,0
D0	32,5820	32,4818	20,3579	12,1947	8,4841	3,7299	2,9693	28,5
E0N	34,3851	33,1416	20,6658	12,3315	8,5611	3,7791	3,0048	27,0
E0S	40,6750	35,9371	22,2382	13,0304	8,9542	4,0307	3,1795	27,5
F0	44,5065	26,2309	16,0678	10,6000	7,3620	2,8667	2,5022	35,0
G0	46,3882	45,0681	28,7506	19,3835	13,9274	5,3686	4,6187	34,5
H0	46,3882	45,0681	28,7506	19,3835	13,9274	5,3686	4,6187	34,5
J0	47,4175	45,5256	29,0079	19,4979	13,9917	5,4098	4,6473	35,0
K0N	49,2206	46,1854	29,3158	19,6347	14,0687	5,4590	4,6828	34,0
K0S	55,5105	48,9809	30,8882	20,3336	14,4618	5,7106	4,8575	34,5



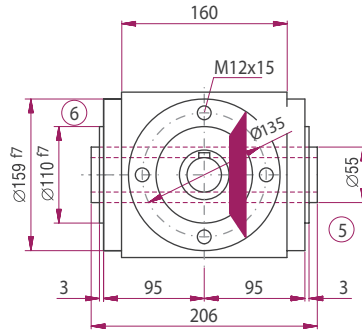
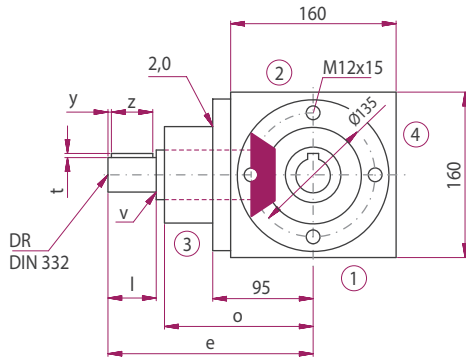

Ausführungen

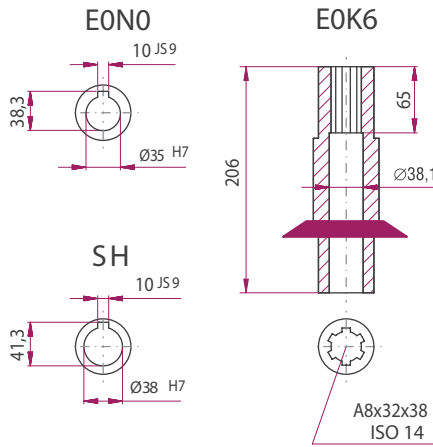
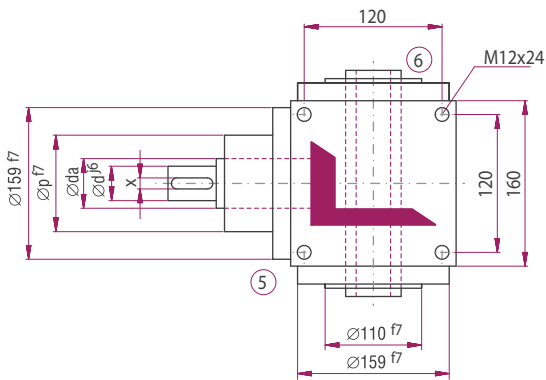

Bauart

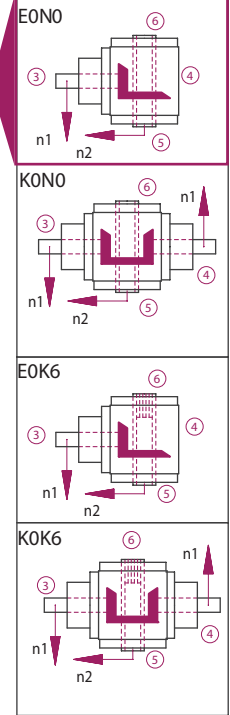

Bauart

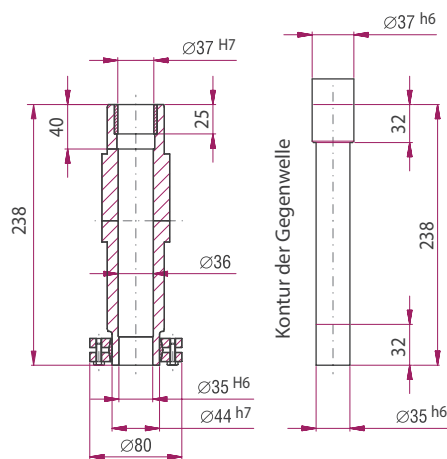
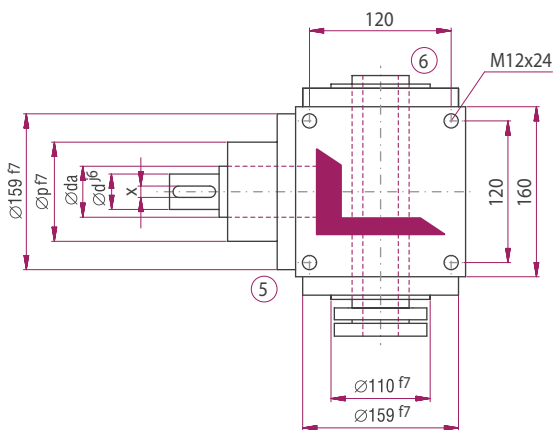
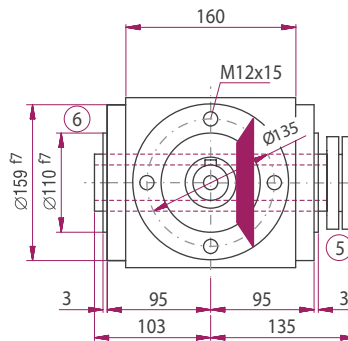
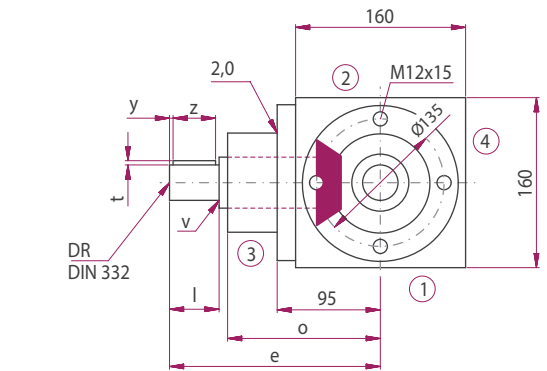
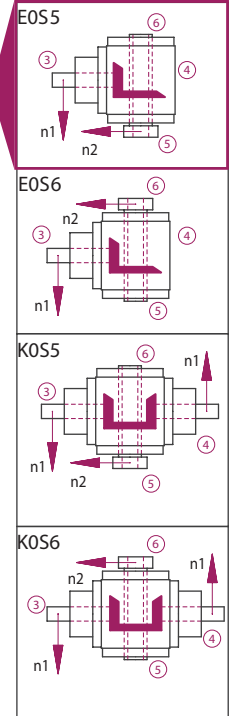

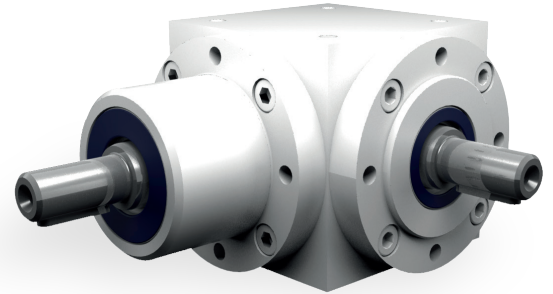

### Eigenschaften

Eigenschaft	Standard
Verzahnung	Kegelradsatz, spiralverzahnt
Gehäuse / Flansche	Grauguss; Stahl
Befestigungs-Gewindebohrung	An allen Gehäuseflächen ohne Flansch und an allen Flanschen.
Welle	Werkstoff 1 C 45, Wellenenden gefettet Passung mit der Toleranz ISO 6 mit Passfedernut: nach DIN 6885 Blatt 1
Hohlwelle	Werkstoff 1 C 45, Wellenenden gefettet Passung mit der Toleranz ISO 7 mit Passfedernut nach DIN 6885 Blatt 1
Radial- Wellendichtring	NBR Form A
Umgebungstemperatur	- 10°C bis + 90°C. Die Werte der Leistungstabellen gelten für + 20°C
Verdreh-Flankenspiel	< 30 arcmin
Schutzklasse	IP 31
Korrosionsschutz	Grundierung; Schichtdicke > 40 µm
Lagerlebensdauer L10h	größer als 15.000 h
Ölwechselintervalle	Bei Einhaltung der Öltemperatur von < 90°C nicht erforderlich Die Lebensdauer der Lager kann um den Faktor 1,5 gesteigert werden, wenn nach den ersten 500 Betriebsstunden und dann alle 5000 Betriebsstunden ein Ölwechsel erfolgt.
Schmierstoff	Synthetische Schmierstoffe

## Leistungsdaten

$n_1$ [1/min]	1:1			1,5:1			2:1			3:1			4:1			5:1			6:1		
	$n_2$ [1/min]	$P_{1N}$ [kW]	$T_{2N}$ [Nm]	$n_2$ [1/min]	$P_{1N}$ [kW]	$T_{2N}$ [Nm]	$n_2$ [1/min]	$P_{1N}$ [kW]	$T_{2N}$ [Nm]	$n_2$ [1/min]	$P_{1N}$ [kW]	$T_{2N}$ [Nm]	$n_2$ [1/min]	$P_{1N}$ [kW]	$T_{2N}$ [Nm]	$n_2$ [1/min]	$P_{1N}$ [kW]	$T_{2N}$ [Nm]	$n_2$ [1/min]	$P_{1N}$ [kW]	$T_{2N}$ [Nm]
3000				2000	72,75	330	1500	51,25	310	1000	46,29	420	750	28,93	350	600	19,84	300	500	11,45	208
2400				1600	63,49	360	1200	45,24	342	800	39,24	445	600	26,45	400	480	17,99	340	400	9,60	218
1500	1500	74,40	450	1000	48,17	437	750	35,13	425	500	28,38	515	375	18,81	455	300	12,57	380	250	6,54	237
1000	1000	56,21	510	667	37,13	505	500	27,56	500	333	20,37	555	250	13,36	485	200	9,26	420	167	4,74	258
750	750	45,88	555	500	30,31	550	375	22,32	540	250	15,98	580	188	10,54	510	150	7,27	440	125	3,98	289
500	500	34,17	620	333	22,57	615	250	16,81	610	167	11,04	600	125	7,23	525	100	5,18	470	83	2,79	304
250	250	19,56	710	167	12,70	690	125	9,37	680	83	5,76	630	63	3,79	550	50	2,78	505	42	1,44	311
50	50	4,13	750	33	2,73	750	25	2,07	750	17	1,29	690	13	0,80	580	10	0,58	525	8	0,28	306
$P_{1Nt}$ [kW]	26,0			26,0			26,0			26,0			26,0			26,0			26,0		
$T_{2max}$ [Nm]	1090			980			980			910			860			960			625		

## Zulässige Radialkraft $F_{r1}$ und Axialkraft $F_{a1}$ an der Welle $N_1$

$n_1$ [1/min]	3000		1000		500		250		100		50	
$T_2$ [Nm]	$F_r$ [N]	$F_a$ [N]	$F_r$ [N]	$F_a$ [N]	$F_r$ [N]	$F_a$ [N]	$F_r$ [N]	$F_a$ [N]	$F_r$ [N]	$F_a$ [N]	$F_r$ [N]	$F_a$ [N]
< 500	2200	1100	1700	850	3200	1600	3900	1950	5000	2500	6200	3100
> 500	1840	920	1420	710	2670	1335	3250	1625	4170	2085	5170	2585

## Zulässige Radialkraft $F_{r2}$ und Axialkraft $F_{a2}$ an der Welle $N_2$

$n_2$ [1/min]	3000		1000		500		250		100		50	
$T_2$ [Nm]	$F_r$ [N]	$F_a$ [N]	$F_r$ [N]	$F_a$ [N]	$F_r$ [N]	$F_a$ [N]	$F_r$ [N]	$F_a$ [N]	$F_r$ [N]	$F_a$ [N]	$F_r$ [N]	$F_a$ [N]
< 500	3200	1600	4300	2150	5000	2500	6500	3250	8000	4000	10000	5000
> 500	2670	1335	3580	1790	4170	2085	5420	2710	6670	3335	8330	4165

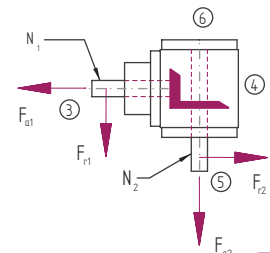

## Massenträgheitsmomente / Masse

Massenträgheitsmoment  $J_1$  auf die schnell-laufende Welle ( $N_1$ ) bezogen

Bauart	Massenträgheitsmoment [kgcm <sup>2</sup> ]								Masse [kg]
	1:1	1,5:1	2:1	3:1	4:1	5:1	6:1		
A0	121,2522	57,6950	36,3095	18,8322	14,2651	6,1470	5,3881	52,0	
B0	174,7000	103,5829	71,6215	34,1931	22,7181	12,8770	10,0616	48,0	
C0	174,7000	103,5829	71,6215	34,1931	22,7181	12,8770	10,0616	48,0	
D0	177,8173	104,9684	72,4008	34,5395	22,9130	13,0016	10,1482	50,0	
E0N	201,3904	109,0276	76,4341	35,2209	23,3588	13,8070	10,7075	48,0	
E0S	222,4124	118,3707	81,6896	37,5567	24,6726	14,6479	11,2914	49,3	
F0	181,8783	84,6400	51,4661	25,5685	18,0543	8,5721	7,0721	60,0	
G0	235,3261	134,3330	92,7745	46,2891	33,1941	16,5990	13,7656	58,0	
H0	235,3261	134,3330	92,7745	46,2891	33,1941	16,5990	13,7656	58,0	
J0	238,4434	135,7185	93,5538	46,6355	33,3890	16,7236	13,8522	60,0	
K0N	262,0165	139,7777	97,5871	47,3169	33,8348	17,5290	14,4115	58,0	
K0S	283,0385	149,1208	102,8426	49,6527	35,1486	18,3699	14,9954	59,3	

Bauart

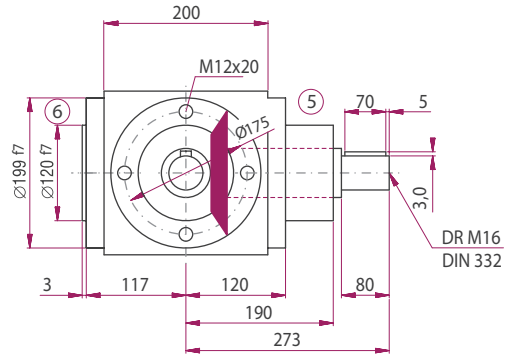
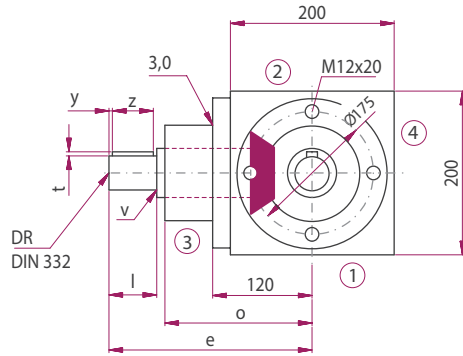
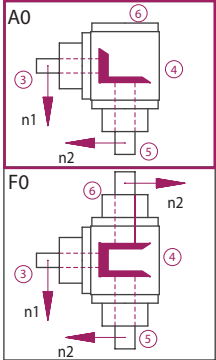

Bauart

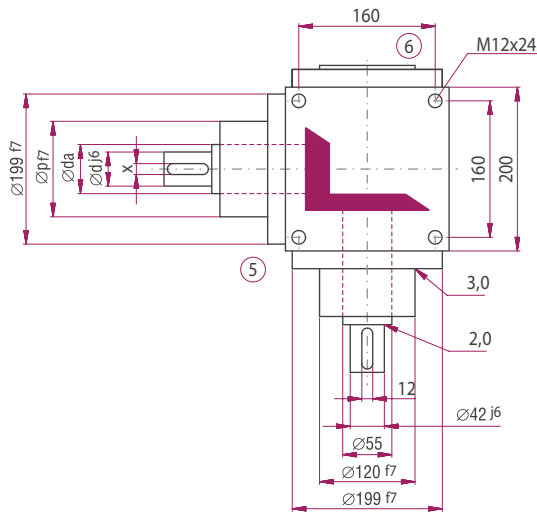
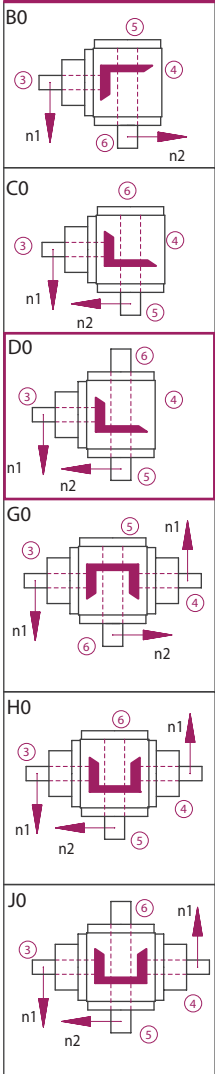

	Übersetzung						
	1:1	1,5:1	2:1	3:1	4:1	5:1	6:1
d [mm]	42	42	42	35	35	28	28
da [mm]	55	55	55	40	40	30	30
l [mm]	80	80	80	68	68	68	68
v [mm]	2	2	2	1	1	0	0
x [mm]	12	12	12	10	10	8	8
y [mm]	5	5	5	3	3	3	3
z [mm]	70	70	70	63	63	63	63
t [mm]	3	3	3	3	3	3	3
e [mm]	273	273	273	261	261	261	261
o [mm]	190	190	190	190	190	190	190
p [mm]	120	120	120	120	120	110	110
DR M	16	16	16	12	12	10	10

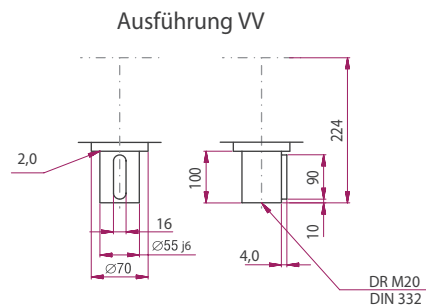
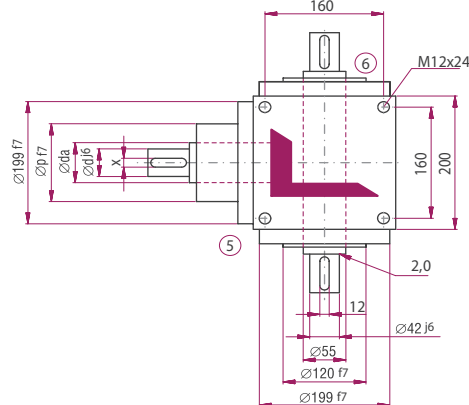
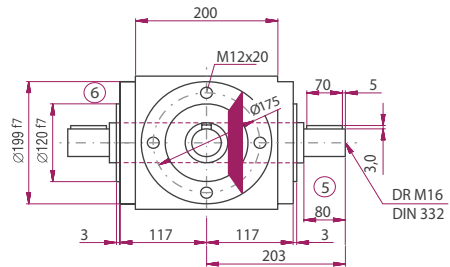
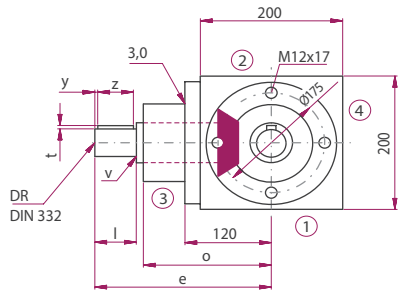

Die Maße der nicht dargestellten Bauarten ergeben sich durch die Spiegelung vorhandener Maße.

Produktkatalog 2024/2025 – Stand 2024-07-16

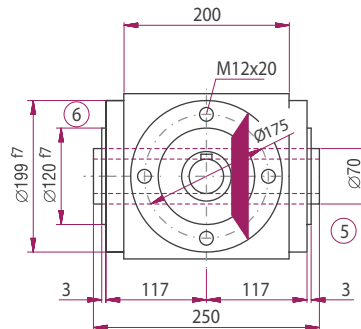
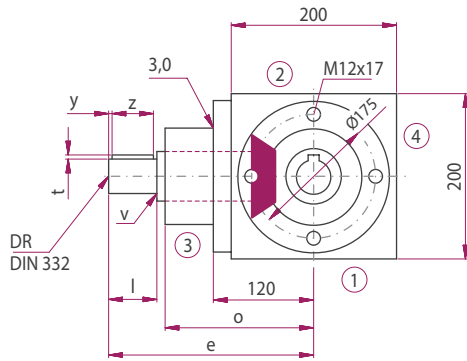

Ausführungen

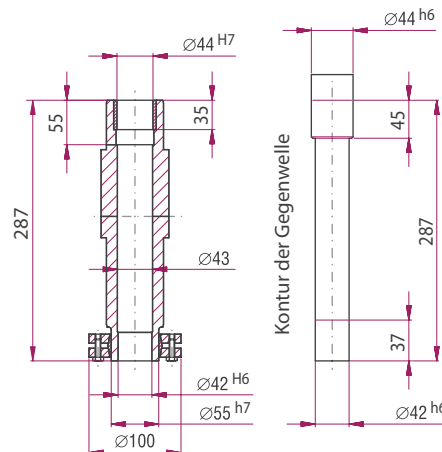
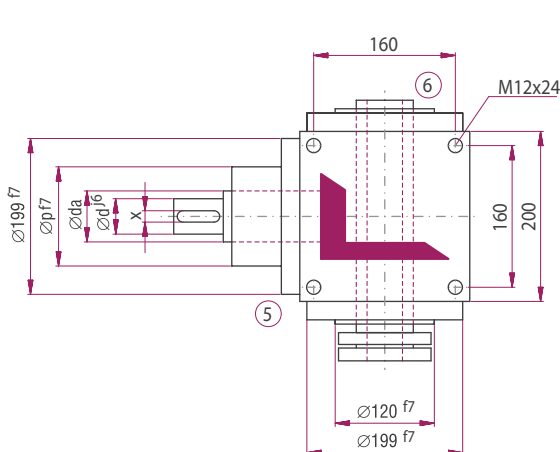
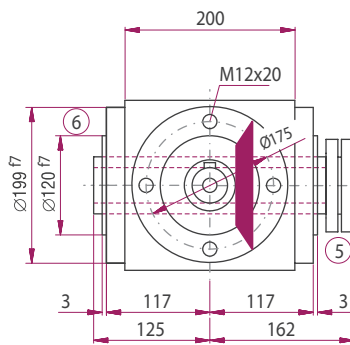
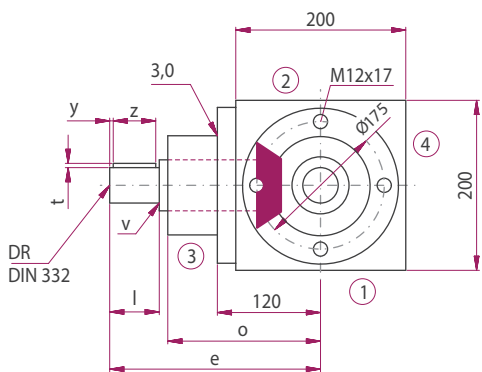
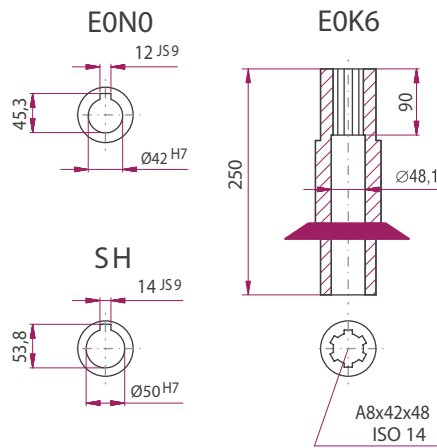
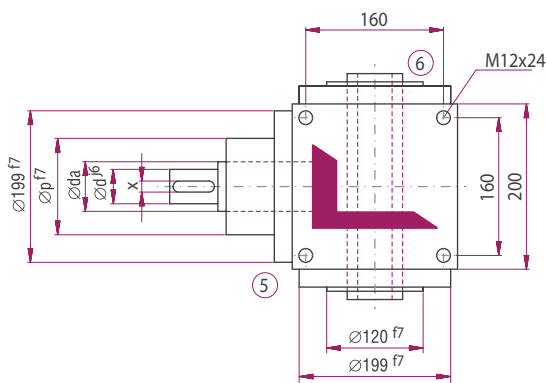

Bauart

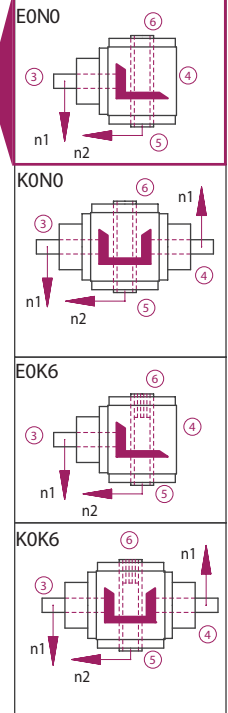

Bauart

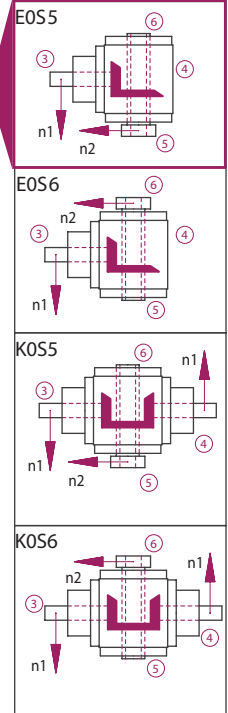

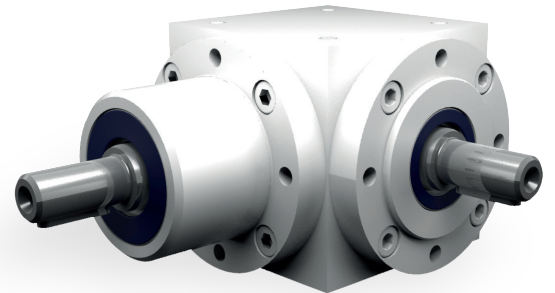

## Eigenschaften

Eigenschaft	Standard
Verzahnung	Kegelradsatz, spiralverzahnt
Gehäuse / Flansche	Grauguss; Stahl
Befestigungs-Gewindebohrung	An allen Gehäuseflächen ohne Flansch und an allen Flanschen.
Welle	Werkstoff 1 C 45, Wellenenden gefettet Passung mit der Toleranz ISO 6 mit Passfedernut: nach DIN 6885 Blatt 1
Hohlwelle	Werkstoff 1 C 45, Wellenenden gefettet Passung mit der Toleranz ISO 7 mit Passfedernut nach DIN 6885 Blatt 1
Radial- Wellendichtring	NBR Form A
Umgebungstemperatur	- 10°C bis + 90°C. Die Werte der Leistungstabellen gelten für + 20°C
Verdreh-Flankenspiel	< 30 arcmin
Schutzklasse	IP 31
Korrosionsschutz	Grundierung; Schichtdicke > 40 µm
Lagerlebensdauer L10h	größer als 15.000 h
Ölwechselintervalle	Bei Einhaltung der Öltemperatur von < 90°C nicht erforderlich Die Lebensdauer der Lager kann um den Faktor 1,5 gesteigert werden, wenn nach den ersten 500 Betriebsstunden und dann alle 5000 Betriebsstunden ein Ölwechsel erfolgt.
Schmierstoff	Synthetische Schmierstoffe

## Leistungsdaten

n <sub>1</sub> [1/min]	1:1				1,5:1			2:1			3:1			4:1			5:1			6:1			
	n <sub>2</sub> [1/min]	P <sub>1N</sub> [kW]	T <sub>2N</sub> [Nm]		n <sub>2</sub> [1/min]	P <sub>1N</sub> [kW]	T <sub>2N</sub> [Nm]	n <sub>2</sub> [1/min]	P <sub>1N</sub> [kW]	T <sub>2N</sub> [Nm]	n <sub>2</sub> [1/min]	P <sub>1N</sub> [kW]	T <sub>2N</sub> [Nm]	n <sub>2</sub> [1/min]	P <sub>1N</sub> [kW]	T <sub>2N</sub> [Nm]	n <sub>2</sub> [1/min]	P <sub>1N</sub> [kW]	T <sub>2N</sub> [Nm]	n <sub>2</sub> [1/min]	P <sub>1N</sub> [kW]	T <sub>2N</sub> [Nm]	
3000					2000	99,20	450	1500	87,63	530	1000	44,09	400	750	36,37	440	600	33,73	510	500	20,17	366	
2400					1600	91,35	518	1200	80,02	605	800	39,68	450	600	32,74	495	480	29,10	550	400	18,08	410	
1500	1500	87,63	530		1000	72,20	655	750	59,11	715	500	29,76	540	375	24,80	600	300	21,00	635	250	13,50	490	
1000	1000	71,65	650		667	56,21	765	500	45,19	820	333	23,33	635	250	18,60	675	200	15,76	715	167	9,92	540	
750	750	60,76	735		500	45,47	825	375	36,79	890	250	19,29	700	188	15,19	735	150	12,73	770	125	7,78	565	
500	500	45,19	820		333	33,79	920	250	26,73	970	167	14,07	765	125	10,95	795	100	9,15	830	83	5,42	590	
250	250	26,73	970		167	20,57	1.120	125	16,88	1.225	83	7,58	825	63	5,99	870	50	5,07	920	42	2,82	610	
50	50	7,00	1.270		33	4,89	1.330	25	3,66	1.330	17	1,63	870	13	1,35	980	10	1,09	990	8	0,57	625	
P <sub>1Nt</sub> [kW]	34,0				34,0			34,0			34,0			34,0			34,0			34,0			
T <sub>2max</sub> [Nm]	1500				1400			1400			1300			1300			1200			1000			

## Zulässige Radialkraft F<sub>r1</sub> und Axialkraft F<sub>a1</sub> an der Welle N<sub>1</sub>

n <sub>1</sub> [1/min]	3000		1000		500		250		100		50	
T <sub>2</sub> [Nm]	F <sub>r</sub> [N]	F <sub>a</sub> [N]	F <sub>r</sub> [N]	F <sub>a</sub> [N]	F <sub>r</sub> [N]	F <sub>a</sub> [N]	F <sub>r</sub> [N]	F <sub>a</sub> [N]	F <sub>r</sub> [N]	F <sub>a</sub> [N]	F <sub>r</sub> [N]	F <sub>a</sub> [N]
< 750	4600	2300	5150	2575	7200	3600	9450	4725	11250	5625	13100	6550
> 750	3832	1916	4290	2145	6000	3000	7876	3938	9376	4688	10918	5459

## Zulässige Radialkraft F<sub>r2</sub> und Axialkraft F<sub>a2</sub> an der Welle N<sub>2</sub>

n <sub>2</sub> [1/min]	3000		1000		500		250		100		50	
T <sub>2</sub> [Nm]	F <sub>r</sub> [N]	F <sub>a</sub> [N]	F <sub>r</sub> [N]	F <sub>a</sub> [N]	F <sub>r</sub> [N]	F <sub>a</sub> [N]	F <sub>r</sub> [N]	F <sub>a</sub> [N]	F <sub>r</sub> [N]	F <sub>a</sub> [N]	F <sub>r</sub> [N]	F <sub>a</sub> [N]
< 750	5850	2925	8650	4325	10500	5250	12250	6125	15000	7500	19000	9500
> 750	4876	2438	7208	3604	8750	4375	10208	5104	12500	6250	15830	7915

## Massenträgheitsmomente / Masse

Massenträgheitsmoment J<sub>1</sub> auf die schnell-laufende Welle (N<sub>1</sub>) bezogen

Bauart	Massenträgheitsmoment [kgcm <sup>2</sup> ]							Masse [kg]
	1:1	1,5:1	2:1	3:1	4:1	5:1	6:1	
A0	506,0000	215,0000	132,0000	55,0000	48,0000	42,0000	37,0000	79,0
B0	502,0000	220,0000	136,0000	57,0000	49,0000	42,0000	38,0000	76,0
C0	502,0000	220,0000	136,0000	57,0000	49,0000	42,0000	38,0000	76,0
D0	512,0000	224,0000	138,0000	58,0000	49,0000	43,0000	38,0000	78,0
E0N	512,0000	229,0000	142,0000	60,0000	50,0000	43,0000	38,0000	71,0
E0S	573,0000	256,0000	157,0000	67,0000	54,0000	46,0000	40,0000	72,0
F0	759,0000	332,0000	201,0000	77,0000	63,0000	53,0000	45,0000	97,0
G0	755,0000	318,0000	200,0000	91,0000	82,0000	72,0000	68,0000	100,0
H0	755,0000	318,0000	200,0000	91,0000	82,0000	72,0000	68,0000	100,0
J0	765,0000	322,0000	202,0000	92,0000	82,0000	73,0000	68,0000	102,0
K0N	765,0000	327,0000	206,0000	94,0000	83,0000	73,0000	68,0000	95,0
K0S	826,0000	354,0000	221,0000	101,0000	87,0000	76,0000	70,0000	96,0



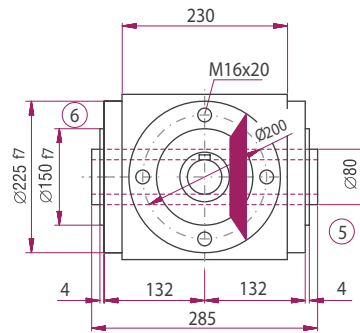
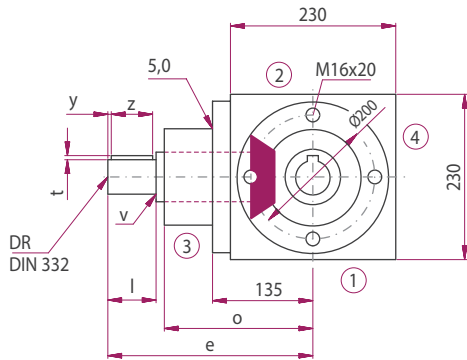

Ausführungen

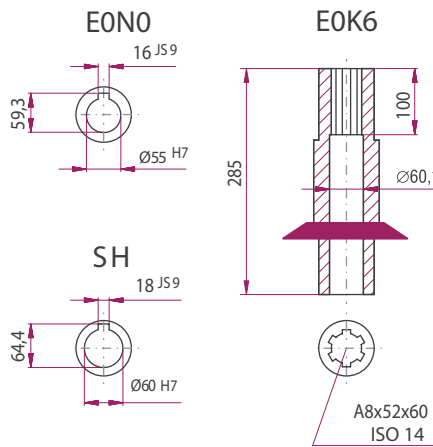
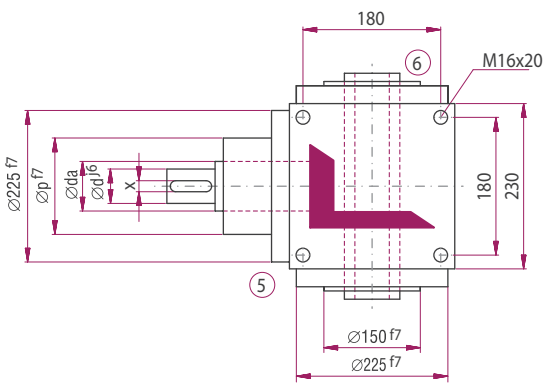

Bauart

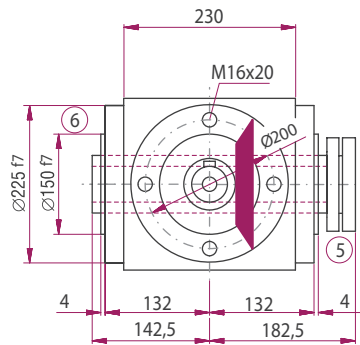
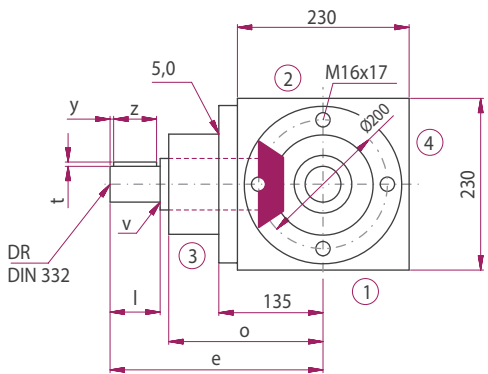
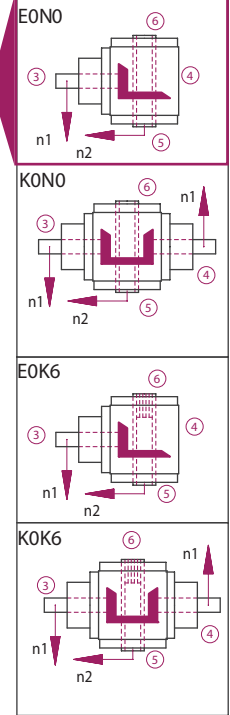

Bauart

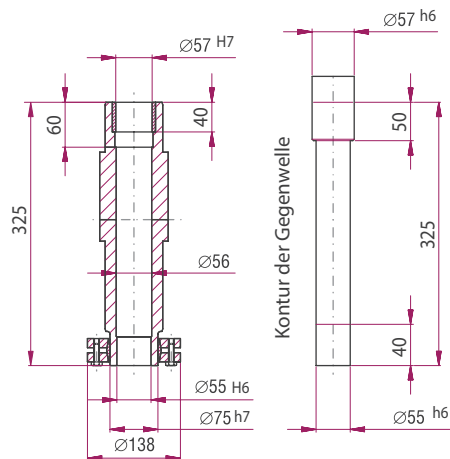
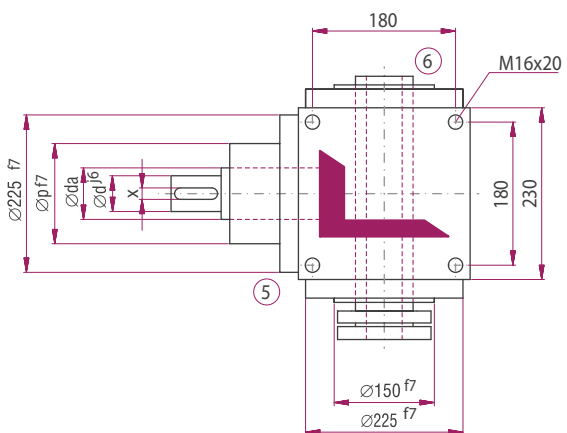
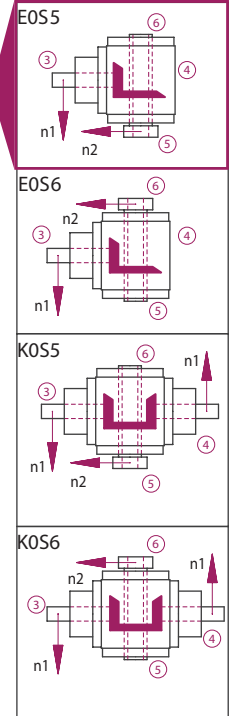

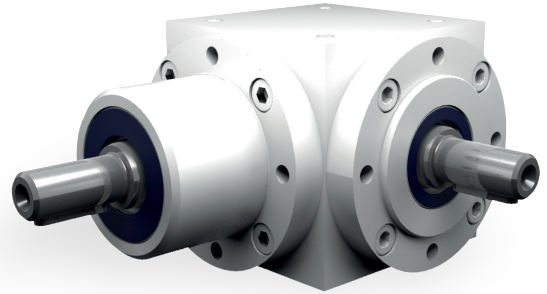

## Eigenschaften

Eigenschaft	Standard
Verzahnung	Kegelradsatz, spiralverzahnt
Gehäuse / Flansche	Grauguss; Stahl
Befestigungs-Gewindebohrung	An allen Gehäuseflächen ohne Flansch und an allen Flanschen.
Welle	Werkstoff 1 C 45, Wellenenden gefettet Passung mit der Toleranz ISO 6 mit Passfedernut: nach DIN 6885 Blatt 1
Hohlwelle	Werkstoff 1 C 45, Wellenenden gefettet Passung mit der Toleranz ISO 7 mit Passfedernut nach DIN 6885 Blatt 1
Radial- Wellendichtring	NBR Form A
Umgebungstemperatur	- 10°C bis + 90°C. Die Werte der Leistungstabellen gelten für + 20°C
Verdreh-Flankenspiel	< 30 arcmin
Schutzklasse	IP 31
Korrosionsschutz	Grundierung; Schichtdicke > 40 µm
Lagerlebensdauer L10h	größer als 15.000 h
Ölwechselintervalle	Bei Einhaltung der Öltemperatur von < 90°C nicht erforderlich Die Lebensdauer der Lager kann um den Faktor 1,5 gesteigert werden, wenn nach den ersten 500 Betriebsstunden und dann alle 5000 Betriebsstunden ein Ölwechsel erfolgt.
Schmierstoff	Synthetische Schmierstoffe

## Leistungsdaten

n <sub>1</sub> [1/min]	1:1			1,5:1			2:1			3:1			4:1			5:1			6:1					
	n <sub>2</sub> [1/min]	P <sub>1N</sub> [kW]	T <sub>2N</sub> [Nm]	n <sub>2</sub> [1/min]	P <sub>1N</sub> [kW]	T <sub>2N</sub> [Nm]	n <sub>2</sub> [1/min]	P <sub>1N</sub> [kW]	T <sub>2N</sub> [Nm]	n <sub>2</sub> [1/min]	P <sub>1N</sub> [kW]	T <sub>2N</sub> [Nm]	n <sub>2</sub> [1/min]	P <sub>1N</sub> [kW]	T <sub>2N</sub> [Nm]	n <sub>2</sub> [1/min]	P <sub>1N</sub> [kW]	T <sub>2N</sub> [Nm]	n <sub>2</sub> [1/min]	P <sub>1N</sub> [kW]	T <sub>2N</sub> [Nm]			
3000				2000	189,58	860	1500	133,92	810	1000	85,97	780	750	57,87	700	600	46,29	700	500	27,27	495			
2400				1600	158,72	900	1200	112,43	850	800	72,39	821	600	51,58	780	480	40,21	760	400	23,12	524			
1500	1500	157,07	950	1000	104,71	950	750	78,53	950	500	49,60	900	375	37,20	900	300	29,10	880	250	16,36	594			
1000	1000	115,73	1.050	667	77,19	1.050	500	57,87	1.050	333	36,34	990	250	28,93	1.050	200	21,82	990	167	12,93	702			
750	750	96,72	1.170	500	64,48	1.170	375	48,36	1.170	250	28,93	1.050	188	22,73	1.100	150	18,19	1.100	125	10,91	792			
500	500	72,75	1.320	333	47,72	1.300	250	35,27	1.280	167	20,43	1.110	125	16,26	1.180	100	13,23	1.200	83	8,06	878			
250	250	42,44	1.540	167	27,43	1.490	125	20,12	1.460	83	11,16	1.220	63	8,61	1.250	50	7,11	1.290	42	4,35	940			
50	50	9,64	1.750	33	6,18	1.700	25	4,55	1.650	17	2,55	1.360	13	1,82	1.320	10	1,47	1.330	8	0,87	951			
P <sub>1Nt</sub> [kW]	42,0			42,0			42,0			42,0			42,0			42,0			42,0					
T <sub>2max</sub> [Nm]	2310			2100			2100			1940			1940			1910			1730					

## Zulässige Radialkraft F<sub>r1</sub> und Axialkraft F<sub>a1</sub> an der Welle N<sub>1</sub>

n <sub>1</sub> [1/min]	3000		1000		500		250		100		50	
T <sub>2</sub> [Nm]	F <sub>r</sub> [N]	F <sub>a</sub> [N]	F <sub>r</sub> [N]	F <sub>a</sub> [N]	F <sub>r</sub> [N]	F <sub>a</sub> [N]	F <sub>r</sub> [N]	F <sub>a</sub> [N]	F <sub>r</sub> [N]	F <sub>a</sub> [N]	F <sub>r</sub> [N]	F <sub>a</sub> [N]
< 950	7000	3500	8600	4300	11200	5600	15000	7500	17500	8750	20000	10000
> 950	5830	2915	7170	3585	9330	4665	12500	6250	14580	7290	16670	8335

## Zulässige Radialkraft F<sub>r2</sub> und Axialkraft F<sub>a2</sub> an der Welle N<sub>2</sub>

n <sub>2</sub> [1/min]	3000		1000		500		250		100		50	
T <sub>2</sub> [Nm]	F <sub>r</sub> [N]	F <sub>a</sub> [N]	F <sub>r</sub> [N]	F <sub>a</sub> [N]	F <sub>r</sub> [N]	F <sub>a</sub> [N]	F <sub>r</sub> [N]	F <sub>a</sub> [N]	F <sub>r</sub> [N]	F <sub>a</sub> [N]	F <sub>r</sub> [N]	F <sub>a</sub> [N]
< 950	8500	4250	13000	6500	16000	8000	18000	9000	22000	11000	28000	14000
> 950	7080	3540	10830	5415	13330	6665	15000	7500	18330	9165	23330	11665

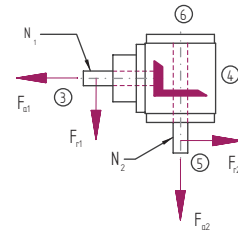

## Massenträgheitsmomente / Masse

Massenträgheitsmoment J<sub>1</sub> auf die schnell-laufende Welle (N<sub>1</sub>) bezogen

Bauart	Massenträgheitsmoment [kgcm <sup>2</sup> ]								Masse [kg]
	1:1	1,5:1	2:1	3:1	4:1	5:1	6:1		
A0	814,200	305,933	194,275	85,0833	46,7738	37,2840	31,8083	85,0	
B0	827,440	168,262	281,335	117,221	66,6638	50,0136	40,7039	85,0	
C0	827,440	168,262	281,335	117,221	66,6638	50,0136	40,7039	85,0	
D0	841,850	383,556	284,938	52,2667	67,5644	50,5900	41,1042	88,0	
E0N	828,690	413,262	287,898	120,110	68,2888	51,0536	41,4261	82,0	
E0S	892,340	441,551	303,810	127,180	72,2656	53,5988	43,1936	84,9	
F0	1221,300	486,867	296,050	130,317	72,2175	53,5680	43,1167	105,0	
G0	1234,540	293,262	373,835	157,071	87,9938	71,0136	61,2039	109,0	
H0	1234,540	293,262	373,835	157,071	87,9938	71,0136	61,2039	109,0	
J0	1248,950	508,556	377,438	92,1167	88,8944	71,5900	61,6042	112,0	
K0N	1235,790	538,262	380,398	159,960	89,6188	72,0536	61,9261	106,0	
K0S	1299,440	566,551	396,310	167,030	93,5956	74,5988	63,6936	108,9	

**Bauart**

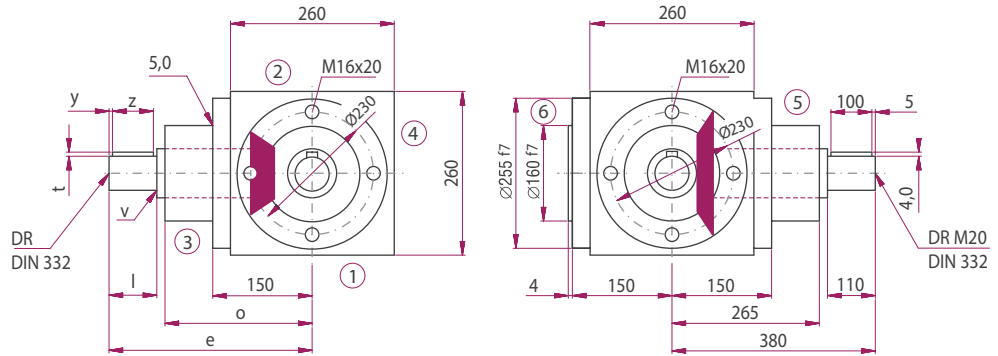
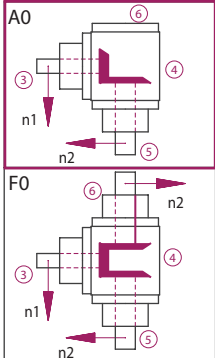

**Bauart**

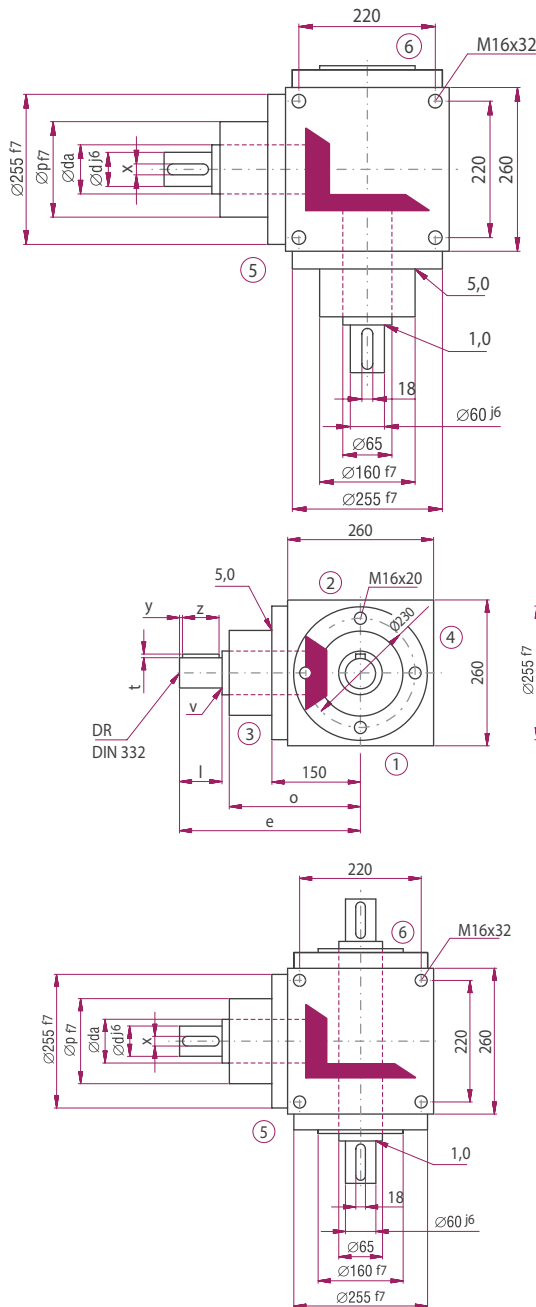
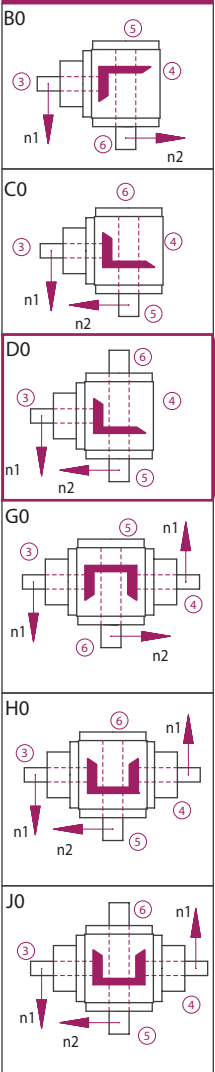

**Übersetzung**

	1:1	1,5:1	2:1	3:1	4:1	5:1	6:1
d [mm]	60	60	60	45	45	45	45
da [mm]	65	65	65	65	65	65	65
l [mm]	110	110	110	90	90	90	90
v [mm]	1	1	1	1,5	1,5	1,5	1,5
x [mm]	18	18	18	14	14	14	14
y [mm]	5	5	5	5	5	5	5
z [mm]	100	100	100	80	80	80	80
t [mm]	4	4	4	3,5	3,5	3,5	3,5
e [mm]	380	380	380	360	360	360	360
o [mm]	265	265	265	265	265	265	265
p [mm]	160	160	160	160	160	160	160
DR M	20	20	20	16	16	16	16

**Ausführung VV**

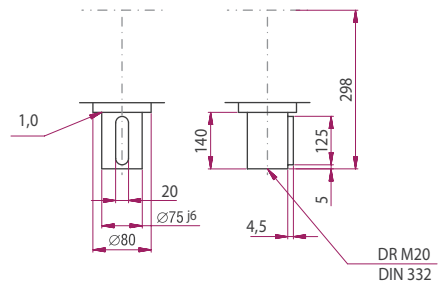

Die Maße der nicht dargestellten Bauarten ergeben sich durch die Spiegelung vorhandener Maße.

Produktkatalog 2024/2025 – Stand 2024-07-16

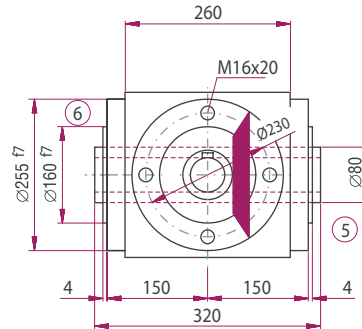
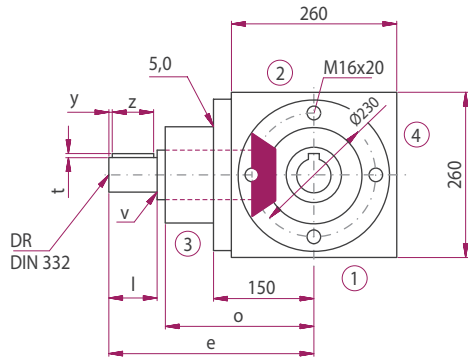

Ausführungen

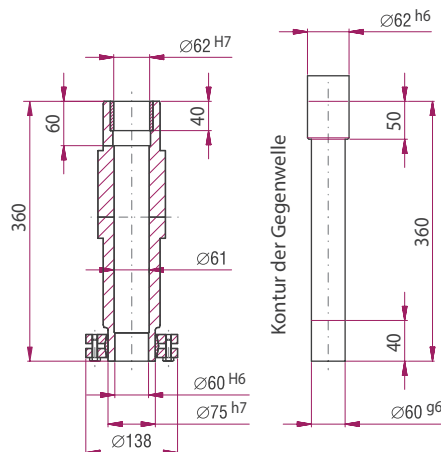
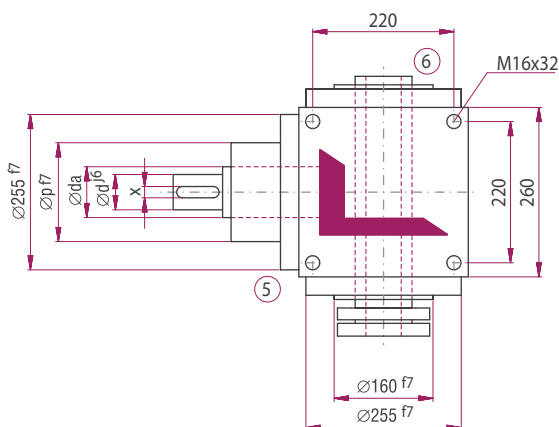
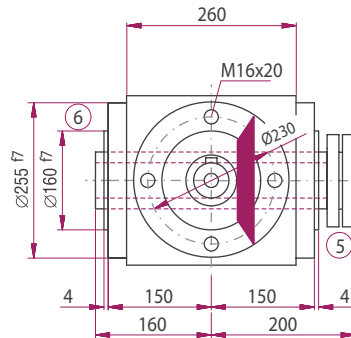
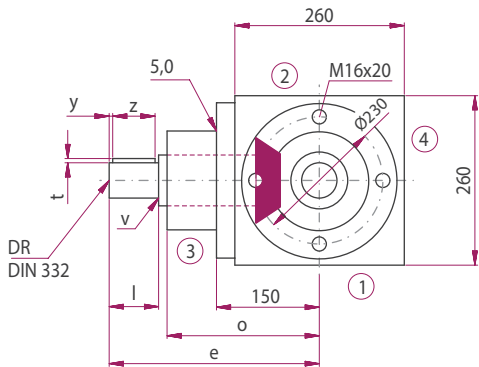
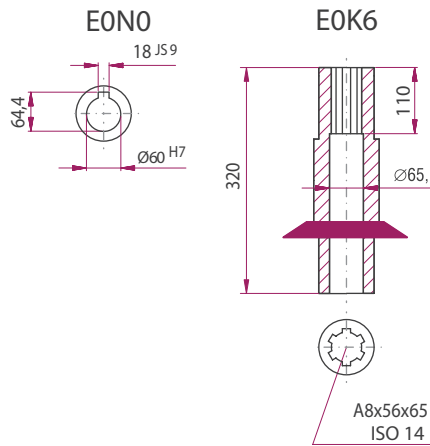
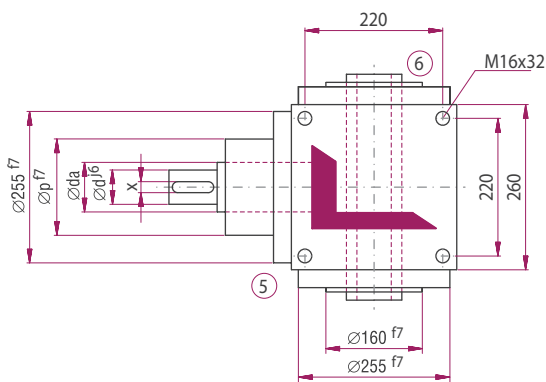

Bauart

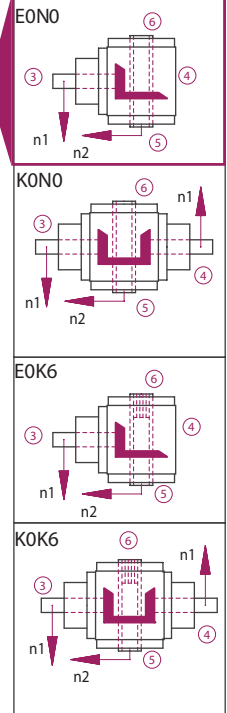

Bauart

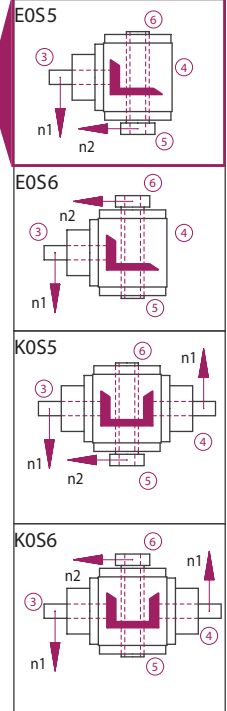

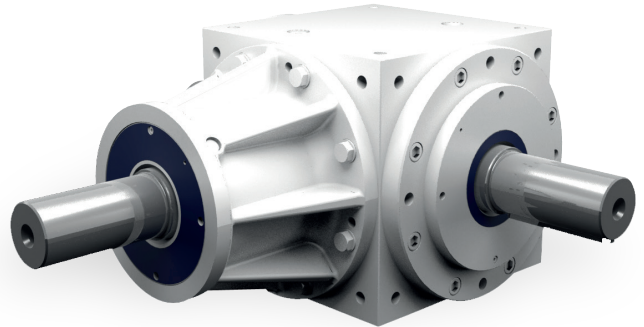

## Eigenschaften

Eigenschaft	Standard
Verzahnung	Kegelradsatz, spiralverzahnt
Gehäuse / Flansche	Grauguss; Stahl
Befestigungs-Gewindebohrung	An allen Gehäuseflächen ohne Flansch und an allen Flanschen.
Welle	Werkstoff 1 C 45, Wellenenden gefettet Passung mit der Toleranz ISO 6 mit Passfedernut: nach DIN 6885 Blatt 1
Hohlwelle	Werkstoff 1 C 45, Wellenenden gefettet Passung mit der Toleranz ISO 7 mit Passfedernut nach DIN 6885 Blatt 1
Radial- Wellendichtring	NBR Form A
Umgebungstemperatur	- 10°C bis + 90°C. Die Werte der Leistungstabellen gelten für + 20°C
Verdreh-Flankenspiel	< 30 arcmin
Schutzklasse	IP 31
Korrosionsschutz	Grundierung; Schichtdicke > 40 µm
Lagerlebensdauer L10h	größer als 15.000 h
Ölwechselintervalle	Bei Einhaltung der Öltemperatur von < 90°C nicht erforderlich Die Lebensdauer der Lager kann um den Faktor 1,5 gesteigert werden, wenn nach den ersten 500 Betriebsstunden und dann alle 5000 Betriebsstunden ein Ölwechsel erfolgt.
Schmierstoff	Synthetische Schmierstoffe

## Leistungsdaten

n <sub>1</sub> [1/min]	1:1			1,5:1			2:1			3:1			4:1			5:1			6:1					
	n <sub>2</sub> [1/min]	P <sub>1N</sub> [kW]	T <sub>2N</sub> [Nm]	n <sub>2</sub> [1/min]	P <sub>1N</sub> [kW]	T <sub>2N</sub> [Nm]	n <sub>2</sub> [1/min]	P <sub>1N</sub> [kW]	T <sub>2N</sub> [Nm]	n <sub>2</sub> [1/min]	P <sub>1N</sub> [kW]	T <sub>2N</sub> [Nm]	n <sub>2</sub> [1/min]	P <sub>1N</sub> [kW]	T <sub>2N</sub> [Nm]	n <sub>2</sub> [1/min]	P <sub>1N</sub> [kW]	T <sub>2N</sub> [Nm]	n <sub>2</sub> [1/min]	P <sub>1N</sub> [kW]	T <sub>2N</sub> [Nm]			
2400										800	160,48	1.820	600	113,75	1.720	480	78,83	1.490	400	56,88	1.290			
1500	1500	267,84	1.620	1000	206,19	1.870	750	200,06	2.420	500	122,35	2.220	375	78,95	1.910	300	56,54	1.710	250	41,61	1.510			
1000	1000	210,53	1.910	667	188,55	2.560	500	155,41	2.820	333	96,26	2.620	250	58,14	2.110	200	42,33	1.920	167	31,41	1.710			
750	750	195,92	2.370	500	141,42	2.560	375	129,37	3.130	250	81,29	2.950	188	47,95	2.320	150	35,88	2.170	125	24,25	1.760			
500	500	155,41	2.820	333	112,63	3.070	250	94,52	3.430	167	59,34	3.230	125	34,72	2.520	100	26,67	2.420	83	16,72	1.820			
250	250	94,52	3.440	167	67,11	3.650	125	54,15	3.930	83	34,26	3.730	63	19,43	2.820	50	16,09	2.920	42	9,28	2.020			
50	50	24,47	4.440	33	16,34	4.500	25	12,79	4.640	17	7,79	4.240	13	4,17	3.030	10	3,56	3.230	8	1,95	2.120			
P <sub>1Nt</sub> [kW]		90,0			90,0			90,0			90,0			90,0			90,0			90,0				
T <sub>2max</sub> [Nm]		5400			5200			5000			4500			3500			3500			2300				

## Zulässige Radialkraft F<sub>r1</sub> und Axialkraft F<sub>a1</sub> an der Welle N<sub>1</sub>

n <sub>1</sub> [1/min]	3000		1000		500		250		100		50		
	T <sub>2</sub> [Nm]	F <sub>r</sub> [N]	F <sub>a</sub> [N]	F <sub>r</sub> [N]	F <sub>a</sub> [N]	F <sub>r</sub> [N]	F <sub>a</sub> [N]	F <sub>r</sub> [N]	F <sub>a</sub> [N]	F <sub>r</sub> [N]	F <sub>a</sub> [N]	F <sub>r</sub> [N]	F <sub>a</sub> [N]
< 2400	14500	7250	15000	7500	17500	8750	22500	11250	27500	13750	33000	16500	
> 2400	12000	6000	12500	6250	14500	7250	18700	9350	23000	11500	27500	13750	

## Zulässige Radialkraft F<sub>r2</sub> und Axialkraft F<sub>a2</sub> an der Welle N<sub>2</sub>

n <sub>2</sub> [1/min]	3000		1000		500		250		100		50		
	T <sub>2</sub> [Nm]	F <sub>r</sub> [N]	F <sub>a</sub> [N]	F <sub>r</sub> [N]	F <sub>a</sub> [N]	F <sub>r</sub> [N]	F <sub>a</sub> [N]	F <sub>r</sub> [N]	F <sub>a</sub> [N]	F <sub>r</sub> [N]	F <sub>a</sub> [N]	F <sub>r</sub> [N]	F <sub>a</sub> [N]
< 2400	17500	8750	18100	9050	21100	10550	26150	13075	34200	17100	40200	20100	
> 2400	14500	7250	15080	7540	17580	8790	21790	10895	28500	14250	33500	16750	

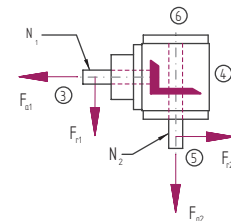

## Massenträgheitsmomente / Masse

Massenträgheitsmoment J<sub>1</sub> auf die schnell-laufende Welle (N<sub>1</sub>) bezogen

Bauart	Massenträgheitsmoment [kgcm <sup>2</sup> ]								Masse [kg]
	1:1	1,5:1	2:1	3:1	4:1	5:1	6:1		
A0	3388,00	1707,00	1021,00	585,000	473,000	296,000	261,000	269,0	
B0	3634,00	1793,00	1063,00	605,000	485,000	304,000	266,000	280,0	
C0	3634,00	1793,00	1063,00	605,000	485,000	304,000	266,000	280,0	
D0	3699,00	1822,00	1079,00	612,000	489,000	306,000	268,000	287,0	
E0N	3459,00	1716,00	1019,00	586,000	474,000	297,000	262,000	259,0	
E0S	3694,00	1820,00	1078,00	612,000	489,000	306,000	268,000	264,0	
F0	5082,00	2593,00	1573,00	805,000	606,000	386,000	317,000	340,0	
G0	5328,00	2613,00	1533,00	969,000	825,000	511,000	471,000	372,0	
H0	5328,00	2613,00	1533,00	969,000	825,000	511,000	471,000	372,0	
J0	5393,00	2642,00	1549,00	976,000	829,000	513,000	473,000	379,0	
K0N	5153,00	2536,00	1489,00	950,000	814,000	504,000	467,000	351,0	
K0S	5388,00	2640,00	1548,00	976,000	829,000	513,000	473,000	356,0	



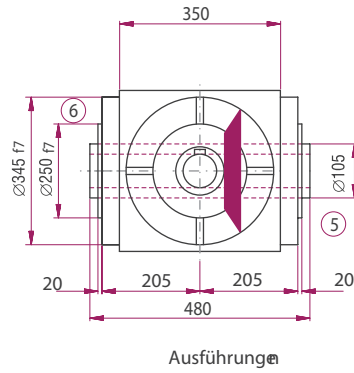
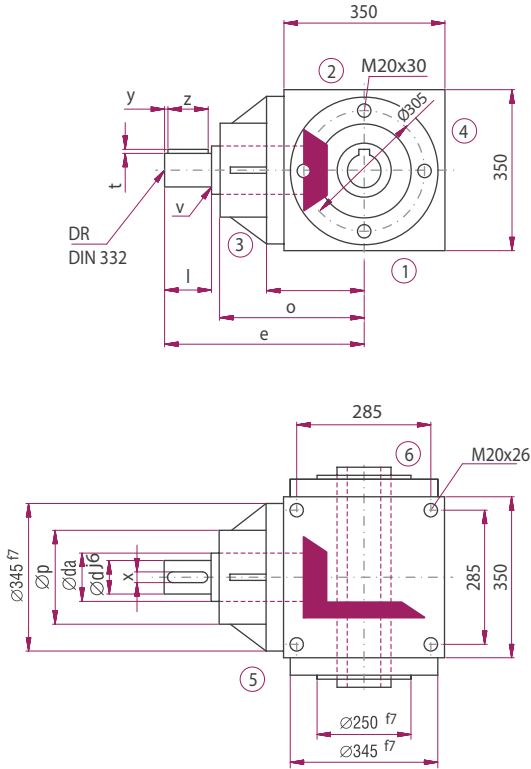

Ausführung

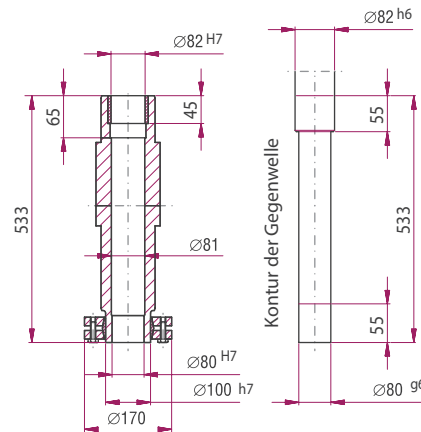
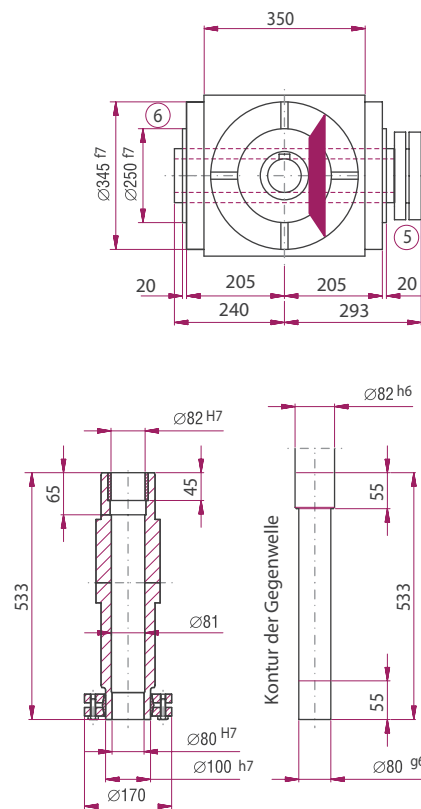
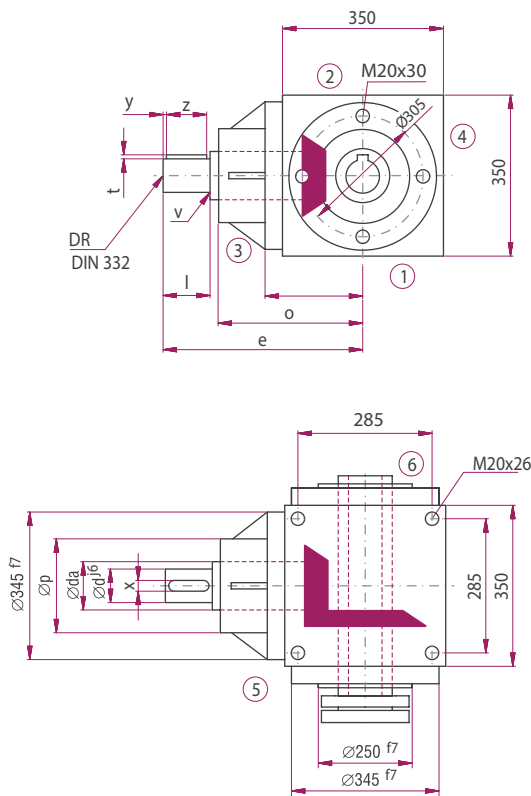
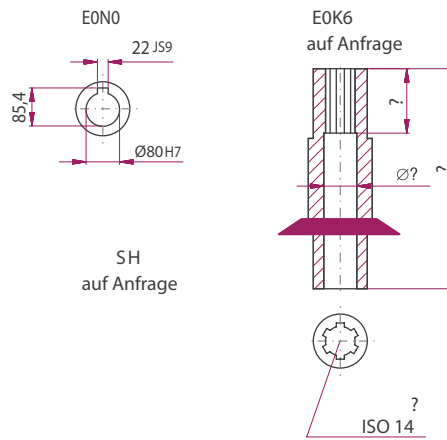

**Bauart**

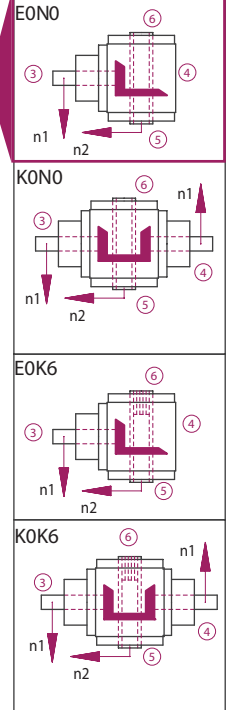

**Bauart**

